



DK20 Series

45 - 58 HP



DK20 SERIES

BRILIANT PERFORMANCE AT THE RIGHT PRICE

The DK10 Series is fully specified to suit any job that demands a durable compact tractor. Ranging from 45 hp to 58 hp, this series of high-performance compact tractors packs impressive power and smooth handling into one dependable workhorse.

CAB or Rear & Mid ROPS
Fuel-Efficient Diesel Engine
Dual HST Pedal (HST Model)

Powerful & Rugged
Excellent Value
PTO Cruise Control



Real Compact

Perfectly designed to fit for orchard, vineyard without damaging crops. Also standard Mid ROPS for narrow T2 model protects a operator from low hanging branches in orchard and vineyard. With compact body size, it is much easier to work and turn in a narrow space (T2 certificate only for narrow model)



Fender Grip (ROPS model)

Easy hop on/off available with fender grips from either side.



High Ground Clearance

The minimum ground clearance helps smooth ride on rocky or uneven terrain.

1 Tiltable Power Steering

The standard power steering reduces considerably the effort in driving necessary to turn frequently or in tight radius.

2 Deluxe Suspension Seat

Ergonomic and adjustable suspension seat allows the operator to ride in comfort and work no matter what the task may be.

3 Single Lever Joystick (CAB Model)

Ergonomically designed Joystick Lever for front loader is standard on DK20 Cab series

HST Linked Easy Speed

When the HST linked pedal is engaged, the HST pedal and the engine rpm are synchronized. This reduces fuel consumption and simplifies tractor operation for a variety of utility and loader applications.

Easy Controls

Dual HST pedals makes operation more convenient and productive for any application.

4 Dual HST Pedal (HST)

Two-pedal system for HST model with smooth engagement makes it even simpler to drive forward and reverse and to control the speed.



EXPERIENCE COMPACT & POWERFUL DK20 SERIES



4WD Engagement

The 4WD comes standard on all models and it is engaged with an easy access lever.



Illuminated Dashboard

The illuminated dashboard ensures great visibility while working in bright daylight or at night.



H-shuttle (for H-shuttle model)

H-shuttle makes your driving much convenient by the front & Rear shuttle controller without engaging the clutch.



Rear Differential Lock

Standard differential lock is accessible easily and it provides best traction to help your driving in sandy, muddy terrain.



Console Tray(Cab Model)

Spacious Console Tray with Cup/Phone holder and power socket is standard on DK20 Cab Series



PTO Cruise

Cruise mode on PTO gives you dependable performance for any tasks with implements in tough conditions.



Powerful HST Transmission (HST Model)

An efficient HST transmission shows guaranteed productivity. The three range (Hi/Mid/Low) transmission with twin pedals helps you simply get your job done.



Eco-Friendly Diesel Engine

The new Common Rail Diesel Engine(CRDI) improves fuel efficiency while reducing noise levels. With this eco-friendly Stage 5 engine, the DK20 series offers a quiet, smooth running and powerful performance.



Hydraulic Independent PTO+ Auto PTO

Rear Independent PTO is easily engaged by the simple turn of a knob. A safety interlock prevents the engine from starting if the PTO switch is left on. All models come standard with a selectable manual or automatic PTO option. When the Auto PTO is engaged, the PTO will automatically shut off when the 3-point control is raised, eliminating exposure to the running implements.



Advanced Air Conditioning System (Cab model)

The improved Cooling and Heating system will ensure the perfect climate control for comfortable working conditions all year round.



Remote Hydraulic Valves

A standard remote valve (4 ports) extends your choice of implements for any attachments and implements.



Tool Box

Spacious tool box is located behind the seat for your convenient.

Modern and Elegant Design

The modern design built on KIOTI tractor provides excellent visibility and self supporting hood enables quick and convenient access for daily maintenance.



SPECIFICATIONS(Manual T/M)

MODEL	DK4520N	DK4520C	DK5020N/HS	DK5020C/CN	DK6020N/HS	DK6020C/CN
ENGINE						
Model	3HT-TM5B	3HT-TM5C	3HT-TM5B	3HT-TM5C	3HT-TM5B	3HT-TM5C
Type	In-line Vertical, Water-cooled, 4 cycle Diesel					
Engine Gross Power	44.9(33.5)		50.3(37.5)		57.7(43.0)	
Total displace	1,826					
Rated Revolution	2,600					
Fuel Tank Capacity	45(11.9)	48(12.7)	45(11.9)	48(12.7)	45(11.9)	48(12.7)
DRIVE TRAIN						
Transmission	Manual / H-Shuttle	Manual	Manual / H-Shuttle	Manual	Manual / H-Shuttle	Manual
Main gear shift x range gear shift	4 x 4					
No. of speeds	16F16R					
shuttle Type	Synchro shuttle		Synchro shuttle / H-Shuttle	Synchro shuttle	Synchro shuttle / H-Shuttle	Synchro shuttle
Steering	Hydrostatic Power Steering					
Hand clutch	N/A		Std. (HS only)	N/A	Std. (HS only)	N/A
Brake type	Wet disc type					
Mechanical differential lock	Rear Standard					
Front wheel drive system	Hydraulic multi disc Clutch					
HYDRAULIC SYSTEM						
3 Point Lift Control Type	Position, Draft, Mixed Control					
Implement Pump	ℓ /min(gpm) 36.4 (9.62)					
Power steering pump	18.7 (4.94)	26 (6.87)	18.7 (4.94)	26 (6.87)	18.7 (4.94)	26 (6.87)
Total hydraulic flow	55.1 (14.56)	62.4 (16.49)	55.1 (14.56)	62.4 (16.49)	55.1 (14.56)	62.4 (16.49)
3-point hitch type	Category I					
Lift capacity at lift point (Max.)	1,717					
Lift capacity at 24 in.behind lift point	kg.f(lbs.) 1,467					
Drawbar type	Drawbar(Clevis)					
No.of standard remote valve's ports (Rear)	4					
TIRE SIZE						
Front AG.	9.5-16	8-16	9.5-16	8-16	9.5-16	8-16
Rear AG.	13.6-24					
TRAVELING SPEEDS						
Forward	km/h 0.34 - 32.8					
Reverse	km/h 0.33 - 32.0					
DIMENSIONS						
Overall Length (Includes 3-pt Hitch)	mm 3,288	3,310	3,288	3,310	3,288	3,310
Overall Width (Minimum Tread)	mm 1,486	1,596	1,596 / Narrow: 1,486			
Overall Height (with ROPS)	mm 2,233	-	2,430 / Narrow: 2,233	-	2,430 / Narrow: 2,233	2,363
Overall Height (Top of Cabin)	mm -	2,363	-	2,363	-	2,363
Wheelbase	mm 1,810					
Min. Ground Clearance	mm 386					
Tread	Front (AG)	mm 1,162	1,284	1,284 / Narrow: 1,162		
	Rear (AG)	mm 1,141	1,251	1,251 / Narrow: 1,141		
Min. Turning Radius (with Brake)	mm 3,420	2,640	2,640 / Narrow: 3,420	2,640	2,640 / Narrow: 3,420	2,640
Weight with ROPS / CABIN	kg.f 1,610 / -	- / 1,848	1,610 / -	- / 1,848	1,610 / -	- / 1,848
Max. permissible weight	kg.f 2,885	3,447	2,885	3,447	2,885	3,447

* NOTE : Specifications and design are subject to change without notice.

STANDARD EQUIPMENT

- Parking Brake
- Electric Panel
- Horn
- Head Lamp
- Signal Lamp
- Fuel Tank Cap
- PTO Cover
- Cup + Phone Holder
- Deck Mat
- Remote Hydraulic Valves (4Ports)
- Auto PTO
- Stationary PTO

OPTIONAL EQUIPMENT

- Front / Rear Working Light (Cab Model Std)
- Power Socket
- Fuel Heater
- Front Weight
- Rear Tire Weight (only for AG Tires)
- Sun Canopy (Rear ROPS)
- Optional PTO KIT (1,000 rpm)
- Stereo (Bluetooth)
- Front Fender

ATTACHMENTS

- Front End Loader

SPECIFICATIONS(HST T/M)

MODEL	DK4520H/CH	DK5020H/CH	DK6020H/CH
ENGINE			
Model	3HT-TH5C		
Type	In-line Vertical, Water-cooled, 4 cycle Diesel		
Engine Gross Power	44.9(33.5)	50.3(37.5)	57.7(43)
Total displace	1,826		
Rated Revolution	2,600		
Fuel Tank Capacity	ℓ(us gal) 48(12.7)		
DRIVE TRAIN			
Transmission	HST		
Main gear shift x range gear shift	3 Range		
No. of speeds	Infinite		
shuttle Type	HST		
Steering	Hydrostatic Power Steering		
Hand clutch	N/A		
Brake type	Wet disc type		
Mechanical differential lock	Rear Standard		
Front wheel drive system	Mechanical		
HYDRAULIC SYSTEM			
3 Point Lift Control Type	Position Control		
Implement Pump	ℓ /min(gpm) 36.4 (9.62)		
Power steering pump	ℓ /min(gpm) 26 (6.87)		
Total hydraulic flow	ℓ /min(gpm) 62.4 (16.49)		
3-point hitch type	Category I		
Lift capacity at lift point (Max.)	1,717		
Lift capacity at 24 in.behind lift point	kg.f(lbs.) 1,467		
Drawbar type	Drawbar(Clevis)		
No.of standard remote valve's ports (Rear)	4		
TIRE SIZE			
Front AG.	8-16		
Rear AG.	13.6-24		
TRAVELING SPEEDS			
Forward	km/h 0 - 29.7		
Reverse	km/h 0 - 20.8		
DIMENSIONS			
Overall Length (Includes 3-pt Hitch)	mm 3,310		
Overall Width (Minimum Tread)	mm 1,596		
Overall Height (with ROPS)	mm 2,233		
Overall Height (Top of Cabin)	mm 2,363		
Wheelbase	mm 1,810		
Min. Ground Clearance	mm 368		
Tread	Front (AG)	mm 1,254	
	Rear (AG)	mm 1,251	
Min. Turning Radius (with Brake)	mm 2,610		
Weight with ROPS	kg.f 1,598		
Max. permissible weight	kg.f 2,885		

* NOTE : Specifications and design are subject to change without notice.

STANDARD EQUIPMENT

- Parking Brake
- Electric Panel
- Horn
- Head Lamp
- Signal Lamp
- Fuel Tank Cap
- PTO Cover
- Cup + Phone Holder
- MID PTO
- Deck Mat
- Remote Hydraulic Valves (4Ports)
- Stationary PTO
- HST Linked Easy Speed (Option for ROPS Models)
- HST Cruise (Option for ROPS Models)

OPTIONAL EQUIPMENT

- Front / Rear Working Light (Cab Model Std)
- Power Socket
- Fuel Heater
- Front Weight
- Rear Tire Weight (only for AG Tires)
- Sun Canopy (Rear ROPS)
- Draw Bar Kit (U)
- Stereo (Bluetooth)
- Front Fender

ATTACHMENTS

- Front End Loader



Front End Loader

The Kioti front end loader is specifically designed for the DK10 series, providing efficient performance with single lever joystick control and a dual lever quick attach bucket. The Kioti loader, with a built in parking stand, is designed to be quickly and easily attached and detached. KL Series loaders utilize the tractor's hydraulic system, feature single-lever control with float and come with a bucket level indicator.

Loader Specifications

MODEL	KL5510N-E-SQA (ROPS) / KL5510N-E-SQC (CABIN)	
A	Maximum Lift Height to Pivot Pin	107.7 in. (2,735 mm)
B	Clearance w/ Bucket Level	96.3 in. (2,446 mm)
C	Clearance w/ Bucket Dumped	78.8 in. (2,001 mm)
D	Reach at Maximum Height (45°)	22.7 in. (576 mm)
E	Maximum Dump Angle	46°
F	Reach w/ Bucket on Ground	71.1 in. (1806 mm)
G	Maximum Rollback Angle	41°
H	Digging Depth Below Grade	8.6 in. (218 mm)
J	Overall Height in Carry Position	54 in. (1371 mm)
L	Bucket Depth (Inner Shell)	18.5 in. (470 mm)
M	Bucket Height	22 in. (560 mm)
N	Bucket Length (Pivot Pin)	26 in. (660 mm)
Lift Capacity to Full Height at Pivot Pins		1,207 kgf / 2,660 lbs
Breakout Force at Pivot Pins		1,769 kgf / 3,900 lbs
Relief Valve Setting (Loader Control Valve)		2,273 psi (195 kg/cm ²)
Rated Flow (Tractor System)		4.2 gpm (16 L/min)
Bucket Weight		125 Kg(66in) , 138 kg(72in) / 276 lbs(66in) , 304lbs(72in)
Approximate Weight (With Bucket)		526 Kg / 1,160 lbs
Bucket Capacity (Heaped)		66 in.: 13.4 cu. ft. / 72 in.: 15.5 cu. ft.
Bucket Rollback Force at Ground Line		3,148 lbs. (1,428 kg)
Single Lever Joystick		KL5520: Optional / KL5521 Standard
Compatible Models		KL5520: ROPS / KL5521 Cab
Cycle Times		2,600 rpm (Full)
Raise Boom Frame		3.9 sec
Lower Boom Frame		2.3 sec
Dump Bucket		3.2 sec
Retract Bucket		1.9 sec

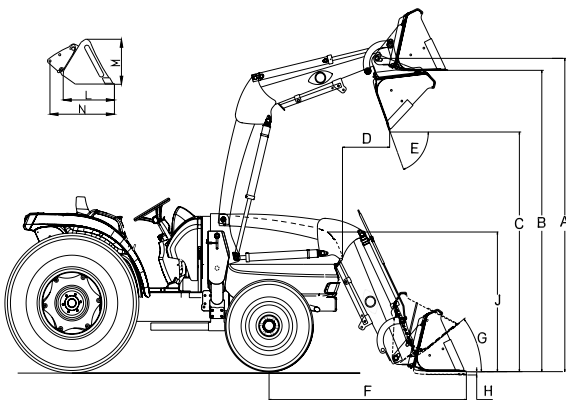

* Specifications and design are subject to change without notice.



Daedong Kioti Europe B.V.
 Koerilenstraat 2-6, 3199 LR, Maasvlakte
 Rotterdam The Netherlands
Tel +31(0)181-35 30 24
Website www.kioti.eu

