



Hako

Instruction Manual

Sweepmaster P1200 RH (6300.10)

Sweepmaster D1200 RH (6300.20)

Introduction

Preface

Dear customer, It is our desire that the good characteristics of the Sweepmaster should justify the confidence you demonstrated by making this purchase. Prior to the first drive, carefully read the chapter "Safety Information" as well, in order to ensure you a safe working with the machine.

Your own safety, as well as the safety of others, depends to a great extent on how the vehicle is moved and operated. Before using the equipment for the first time, read this original manual thoroughly, act according to the information contained and keep it in a safe place for future reference or subsequent owners. The manual provides valuable information about operation, service and maintenance. The warning symbols as used in this manual identifies items relevant to safety. Please observe the safety provisions (see chapter "Safety Information").

Your authorised Hako dealer will be pleased to answer further questions regarding the vehicle or the operation and maintenance manual.

Please be advised explicitly that we cannot accept any legal issues out of the contents of this manual. If repair work has to be performed make sure that only genuine spare parts are used; only genuine spare parts may guarantee a dependable machine. We reserve the right for technical improvement.

Valid as of: August 2019

Hako GmbH
D-23843 Bad Oldesloe
Hamburger Str. 209-239
Telephon +49 4531 806-0

Proper use

The Sweepmaster is a sweeper intended for commercial use and has been exclusively designed for collecting dry and moist matter from floor surfaces in e.g. factories, storage buildings, parking grounds and pedestrian areas. Using the machine beyond this scope of application will be deemed improper use; The manufacturer cannot be held liable for consequential damages; the user alone bears the risk. The Sweepmaster is not suitable for collecting toxic, combustible or other matters which are hazardous to health. The term of proper use also includes operation, maintenance and repair work to be performed in compliance with the manufacturer's specifications. The Sweepmaster may only be used by persons that are familiar with the machine and aware of possible hazards involved. The applicable Accident Prevention Regulations and further regulations in vigour concerning aspects of safety and working medicine will have to be complied with. Based on the conception, design and construction of the model introduced

Introduction

onto the market by us, the machine complies with the applicable basic safety and health requirements stipulated in the EC Directive (refer to Declaration of Conformity). This declaration is no longer considered valid in the event of modifications to the machine not authorized by us. The manufacturer is not deemed liable for any damage resulting from unauthorized modifications to the machine.

Notes on warranty

The terms of the sales contract apply. Damages are not subject to warranty if they are due to non-compliance with the maintenance and service provisions. The maintenance work has to be performed by an authorized Hako service center and confirmed in the "Maintenance certificate" which is the warranty document.

The following is excluded from warranty: fuses, natural wear, damages caused by overload, inexpert handling and unauthorized modification of the machine. Moreover, any claim for warranty cannot be accepted if damages of the machine are caused by fitting parts or accessories without Hako's prior and

explicit consent or by non-compliance with the maintenance instructions.

Acceptance of the machine

Upon arrival, check machine for possible damages in transit. Follow unpacking instructions on shipping pallet. Each unit has been tested and thoroughly inspected before shipment. Any damage is the responsibility of the delivery carrier who should be notified immediately.

Disposing of the machine

Render the machine inoperable. It must not represent a source of risks to children. Dispose of the machine in accordance with the applicable local regulations. For further information on disposal and recycling, contact the authorized Hako dealer where you purchased the machine.

Used batteries with the recycling symbol contain reusable commodities. The heavy metals contained simultaneously represent a serious risk to health and to the environment. Never open batteries or damage them. Never touch, inhale or swallow any material inside batteries. Health hazard! Never allow batteries to pollute the environment. Risk of contaminating the ground and water! In ac-

cordance with the symbol with the crossed out bin, these batteries must not be disposed of in domestic waste. The return and recycling of old batteries must be agreed on with your authorized Hako dealer in accordance with the Battery Law § 6 and § 8 (BattG).

Regulations for Approval

According to §18 of the German Motor Vehicle Construction and Use Regulations (StVZO), the Sweepmaster is an automotive machine. The manufacturer supplies the expertise required for type approval. On the base of this expertise, the local approval authority submits the valid type approval.

Unnecessary is a registration number. According to §29 of the German Motor Vehicle Construction and Use Regulations (StVZO) is a general inspection unnecessary too, as the type definite maximum speed is minor 20km/h.

According to the German Motor Vehicle Construction and Use Regulations (StVZO), the machine has to be equipped with first aid kit, warning triangle and the type approval certificate when being used on public roads, paths and places. Any modification carried out at the

Introduction

Sweepmaster and having an influence on the type approval specifications and are not indicated there will render the type approval invalid. Before receiving a new type approval, the machine has to be presented to an authorized expert for issue of new expertise. This expertise turns type approval after being stamped by approval authority..

Driving Licence

According to the Driving Licence Act, any person who is driving a vehicle running at a construction-defined maximum speed of 6 km/h or more on, public roads, paths and places has to hold a valid driving licence. A driving licence of the class L is required for driving the Sweepmaster (automotive machine up to a speed of 25km/h).

Table of contents



Introduction	2	3	Operation	20	5.8.2 Check Engine Oil Level	47
Preface	2	3.1 Working Procedure	20	5.8.3 Cleaning the radiator	48	
Proper use	2	3.1.1 Sweeper Roller	21	5.8.4 Checking the coolant level . . .	49	
Notes on warranty	3	3.1.2 Side Broom	21	5.8.5 Air Cleaner	50	
Acceptance of the machine	3	3.1.3 Steering	21	5.9 Hydraulic System	51	
Disposing of the machine	3	3.1.4 Filter System		5.9.1 Check Hydraulic		
Regulations for Approval	3	Dust Evacuation	22	Fluid Level	52	
Driving Licence	4	3.1.5 Shaking System	22	5.9.2 Refill Hydraulic Fluid	53	
1 Safety information	6	3.1.6 Brake	23	5.10 V-Belt Drive	54	
1.1 Safety and Warning Symbols . .	6	3.1.7 Travel Drive Assembly	23	5.11 Electric System	55	
1.2 General Provisions	7	3.1.8 Hydraulic System	23	5.11.1 Fuses and relays	55	
1.3 Provisions for Operation	7	3.2 Operating Elements	24	5.11.2 Batterie	56	
1.4 Maintenance instructions	8	3.2.1 Control Panel	26	5.12 Special Equipment and		
1.5 Specific Hazards	10	3.2.2 Emptying of the Dirt Hopper . .	31	Spare Parts	57	
1.6 Information for Protection of En- vironment	11	4 Technical Data	33	EC-Declaration of Conformity		
1.7 Labels at the Machine	12	5 Maintenance and Care	38	59		
2 First Operation	16	5.1 Maintenance Schedule	39			
2.1 Instruction	16	5.2 Mount/Dismount Sweeper Roll- er	41			
2.2 Initial charging procedure	16	5.3 Adjust Sweeping Track	42			
2.3 Before Putting into Operation . .	16	5.4 Sealing Strips for				
2.4 Start Machine	16	Broom Compartment	43			
2.5 Operation	17	5.5 Replace Side Broom	43			
2.6 Machine stopping and parking . .	17	5.6 Dismount Plate Filter	44			
2.7 After work	17	5.7 Basic Cleaning of Plate Filter . .	45			
2.8 Transport rides and Towing	18	5.8 Engine	46			
		5.8.1 Checking the supply	46			

Safety information

1 Safety information

1.1 Safety and Warning Symbols

All paragraphs in this manual referring to your personal safety, the safety of your machine and the environment protection are attributed one of the following warning symbols:

Symbol	Hazardous for...	Description
Safety Provisions 	persons and goods	Safety Provisions in dangerous situation caused by misuse inaccurate adherence of instructions or prescribed work routine.
CAUTION 	the machine	important information on handling the machine in order to maintain operability.
Ecological hazard 	the environment	due to use of substances representing an inherent danger to health of environment

Safety information

1.2 General Provisions

- Apart from the provisions contained in this instruction manual, the general safety provisions and the accident prevention regulations as imposed by law have to be complied with.
- Before taking your machine into operation, carefully read the instruction manual as well as other separate instructions for accessories or attached implements and comply with all points mentioned there during work.
- Persons being trained by qualified Hako technicians only are authorised to operate, service and repair the machine.
- This vehicle is not intended to be used by persons (including children) with limited physical or mental capabilities or persons without sufficient experience and ability.
- You are advised to thoroughly study the safety instructions since precise knowledge only helps avoiding errors during operation of the machine and thus guarantee faultless usage of the machine.
- The operating instructions have to

be at hand at the place of use of the machine, and therefore have to be kept readily available at the machine.

- When selling or letting the machine for rent, hand out these documents to the new owner/operator and have the transfer certified!
- The warning and instruction plates attached to the machine contain valuable advice about safe operation. Immediately replace incomplete or illegible labels.
- As far as safety standards are concerned, spare have to equal genuine spare parts!

1.3 Provisions for Operation

- Before taking into operation, check the machine for operational safety! Immediately remedy malfunctions!
- It is indispensable for the operator to get acquainted with all attached implements and controls as well as with their function before operation begins. Once you have started to work, no time will be left to do so!
- When working with the machine use firm and skid proof shoes.
- The machine may be used only on

such surfaces clearly specified by the owner or his authorised representative.

- When working with the machine, pay strict attention to any persons in the close vicinity.
- The machine is not designed for collecting hazardous, inflammable or explosive dusts or substances.
- This machine must not be used as dust-evacuating machine with dust filter insert (separator) to collect dusts which are hazardous to health.
- Usage of the machine in explosive areas is prohibited.
- Pull the ignition key to avoid unauthorized use of the machine.
- Before commencing work, the operator has to make sure that the machine and its accessories are in proper and safe condition. Machines with known defects must not be used.
- Before operation of the machine, adjust driver's seat such that complete visibility of the riding track and the rear working area is given!
- For safety reasons, the driver's seat is equipped with a seat contact switch. Function of this contact

Safety information

- switch must not be bypassed!
 - Disengage all drive systems before cranking the engine.
 - The machine may be started, run and stopped by a person seated on-ly.
 - Never let the engine run in indoor areas! Intoxication hazard!
 - Provide for sufficient ventilation when sweeping indoors (dust and combustion gas). Intoxication hazard!
 - Always adapt the driving speed to the ambient conditions and the loading state.
Compared to four-wheeled vehicles, driving stability of three-wheeled vehicles is reduced, therefor:
Abrupt steering manoeuvres at higher speed or negotiating curves at high speed may cause tipping of the articulated vehicle.
Do not turn at slopes but on level ground only
Ride up- and downhill straight.
Avoid taking sudden curves when riding up- or downhill or across to the slope.
 - In slope there is tilting danger.
 - The machine may be used only for operation on areas with a maximum inclination of up to 18 %.
 - Do not exceed the admissible total weight and the admissible axle load limits. Check the dirt hopper filling level frequently.
 - Before lifting or lowering the dirt hopper make sure that no persons, animals or other obstacle are in the area of operation.
 - Pinching and shearing hazard. Provide for required safe distance before lifting or lowering the dirt hopper.
 - It's only allowed to lift up the dirt hopper in immediately nearness of the container.
Emptying the dirt hopper on level and solid floor.
 - Do not sweep when the dirt hopper is lifted.
 - By emptying the dirt hopper pay attention to bystanders.
 - Proceed to filter shaking only if the dirt hopper is in closed position.
 - Pay attention to hot parts for example coolant, tubes of the exhaust etc.
- ### 1.4 Maintenance instructions
- The daily and weekly maintenance and repair task must be performed by a qualified operator. For any further maintenance and repair work beyond please contact your local Hako service center.
 - Observe the maintenance activities and intervals set out in the instruction manual.
 - Maintenance and repair work may be carried out only by means of appropriate tools.
 - Have the machine checked for safe condition in the sense of the Accident Prevention Regulation by an expert at regular intervals (recommendation: at least once yearly) as well as after modifications or repair.
 - Spare parts have to equal the technical requirements as specified by the manufacturer! Genuine spare parts guarantee compliance with these requirements.
 - Use of other than the sweeper rollers and side brooms approved by the manufacturer is not admitted (see technical data) since use of other sweeper rollers and side brooms may affect your safety.
 - Use of other than the air- and oilfilters approved by the manufacturer is not admitted (see technical data)

Safety information

since use of other air- and oilfilters may affect your safety.

- Switch off the engine and remove the key before inspecting the machine or performing any maintenance work.
- Risk of scalding from hot coolant! The cooling system is under pressure. Allow the engine to cool down.
- Danger of burns from hot parts! Do not touch any parts such as engine block, cooling system and exhaust system during operation and for some time after. Allow the engine to cool down.
- Proceed to cleaning of the dirt hopper in regular intervals to preclude formation of bacterial deposits.
- The machine is splash-proof (IPX3). Cleaning the machine by means of high-pressure cleaning equipment or by vapour jet is prohibited.
- Shut the motor down before transporting the machine.
- After having jacked the Sweepmaster by means of a car lifter, additionally support the machine adequately.
- No person is allowed to be in the jacked or lifted-up Sweepmaster.
- Before changing wheels protect the machine against rolling by placing

wedges.

Proceed to wheel changing when the machine is on level and solid ground.

- Do not remove, install or repair a tire on the rim. Contact a tire workshop for works at tires and rims. Such workshops have qualified personnel as well as special safety tools at disposal.
- Do not proceed to welding, boring, sewing or grinding at the vehicle's frame. Only Hako-workshops are authorized to replace damaged parts.
- Use genuine fuses only. Use of higher-level fuses may damage the electric system. Risk of fire.
- When working at the electric system disconnect the negative pole of the battery.
- Do not keep batteries discharged for a longer period, always recharge them as soon as possible.
- Top with distilled water only. Never refill battery acid in battery cells of perfect condition.
- Keep batteries dry and clean and clear of soiling such e.g. metallic dust to avoid leakage current.
- Battery acid is highly caustic (keep clear of children).

When checking the battery acid level, wear safety glasses. If acid splashes get into the eyes rinse with clear water for 15 minutes and contact a doctor immediately.

Use appropriate protective means (e.g. protective gloves or finger-stalls) when handling battery acid. Do not use open flames (explosion hazard).

- Pinching and shearing hazard by fitting, removal and change of the battery.
- All liquids escaping under high pressure (such as e.g. coolant, fuel oil or hydraulic liquid) may penetrate the skin and cause heavy injuries. Contact a doctor immediately in order to avoid infections. Take all precautions before draining boiling oil - burning hazard.
- Inspect the braking system at regular intervals. Hako-workshops or approved brake service centres only are authorized to proceed to adjustment or repair work of the brake system.
- Inspect the hydraulic system at regular intervals. Hako-workshops only are authorized to proceed to adjust-

Safety information

ment or repair work of the hydraulic system.

- Check hydraulic hoses and lines for leakage or damages in regular intervals. Replace defective hoses and lines immediately.

1.5 Specific Hazards

Safety equipment

- Do not operate the Sweepmaster without safety equipment being installed (all cover parts of the machine).

Refill fuel oil

- The utmost caution is advised when handling fuel oil - fire hazard! Never refuel in the vicinity of open flames or ignitable sparks! Do not smoke while fuelling! Turn engine off, pull ignition key and engage parking brake before fuelling. Never refill fuel oil in closed rooms! Wipe away spilled fuel oil!

Electric system

- Only use genuine fuses with prescribed connecting load.
- In case of malfunction of the electric system, immediately shutdown machine and remedy.
- Qualified personnel only is autho-

rised to proceed to works at the electrical equipment and only according to electro-technical rules.

- Inspect/check the electrical equipment of the machine at regular intervals. Immediately remedy defects such e.g. loose connections or scorched cables.
- Respect the operating instructions of the battery manufacturer.
- Never place metal objects or tools on batteries - short-circuit hazard!
- Provide for sufficient ventilation of areas where batteries are charged. – Explosion hazard!
Open seat hood by loading the batteries.

Safety information

1.6 Information for Protection of Environment

- For safe use of substances inheriting a danger to health and environment specific knowledge is required.
- During maintenance and repair, all operating media have to be collected in adequate receptacles. Provide for disposal in compliance with the legal provisions according to the Waste Disposal Act and the Used Oil Act.
- Do not let leaking oil, diesel oil, lubricants or other substance penetrate the soil. Danger of ground water soiling. Wipe away spilled fluids and provide for disposal according to the regulations.
- Depending on the filtered substances, used filter inserts are considered special waste in most cases and have to be disposed of accordingly.
- Batteries contain highly caustic sulphuric acid. Batteries have to be handled with utmost caution. Old batteries are considered special waste and have to be disposed of accordingly.
- Used batteries labelled as recyclable contain reusable economic goods.

According to the crossed dustbin label these batteries must not be added to the normal waste. Provide for agreement with the Hako contract dealer on return and disposal according to § 8 BattV.

Safety information

1.7 Labels at the Machine

The following safety and information labels are legibly attached to the vehicle. Replace missing or illegible labels immediately.

Hako nameplate front (Fig. 1/1) and rear (Fig. 2/1)

Vehicle identification number (Fig. 1/2)



Instruction manual (Fig. 1/3)



Ignition lock (Fig. 1/4)

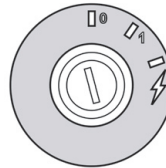

Brake (Fig. 1/5)

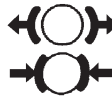

Parking brake (Fig. 1/6)



Folding apron (Fig. 1/7)



High-pressure cleaner
Steam cleaner (Fig. 1/8)



Inflation pressure (Fig. 1/9)

6 Bar

Lifted-up disposal function (Fig. 1/10)

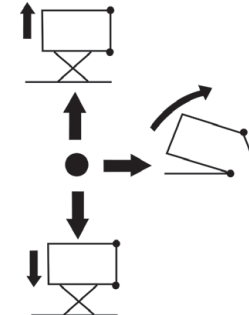

Safety information

Sound power/Rise (Fig. 1/11)
Sweepmaster P1200 RH



Sweepmaster D1200 RH



Adjust sweeping track side broom
(Fig. 1/12)



Maximum speed (Fig. 1/13) and (Fig. 2/9) (option)



Pinching hazard (both sides) (Fig. 2/2)



Fuel (Fig. 2/3)
Sweepmaster P1200 RH
Gasoline
Sweepmaster D1200 RH
Diesel (low-sulfur)

Burning surface (Fig. 2/4)



Sweeper roller wearing take-up
(Fig. 2/5)

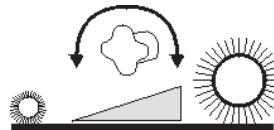

Rotating parts (Fig. 2/6)



Hydraulic fluid (Fig. 2/7)



Type name/QR-Code Sweepmaster
(Fig. 2/8)

Sweepmaster P1200 RH
Sweepmaster D1200 RH



Safety information

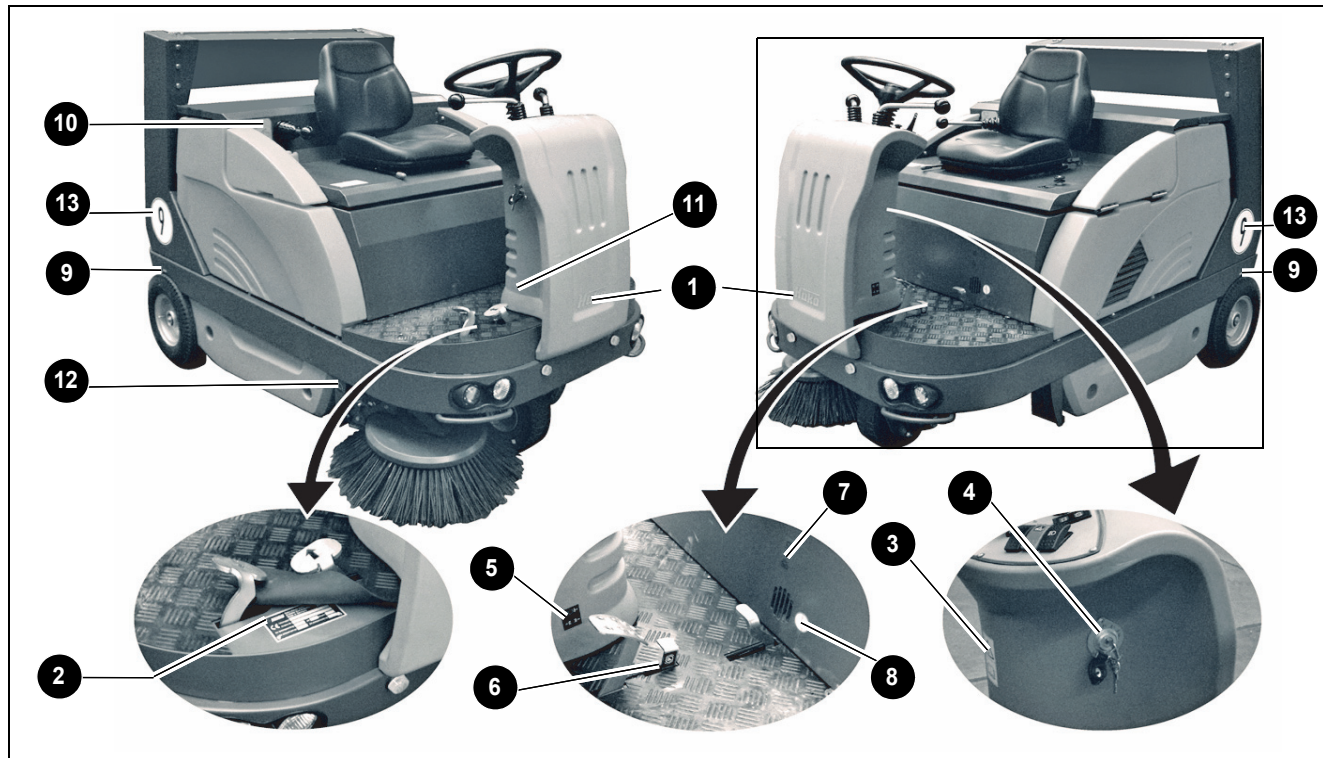

Fig.1

Safety information

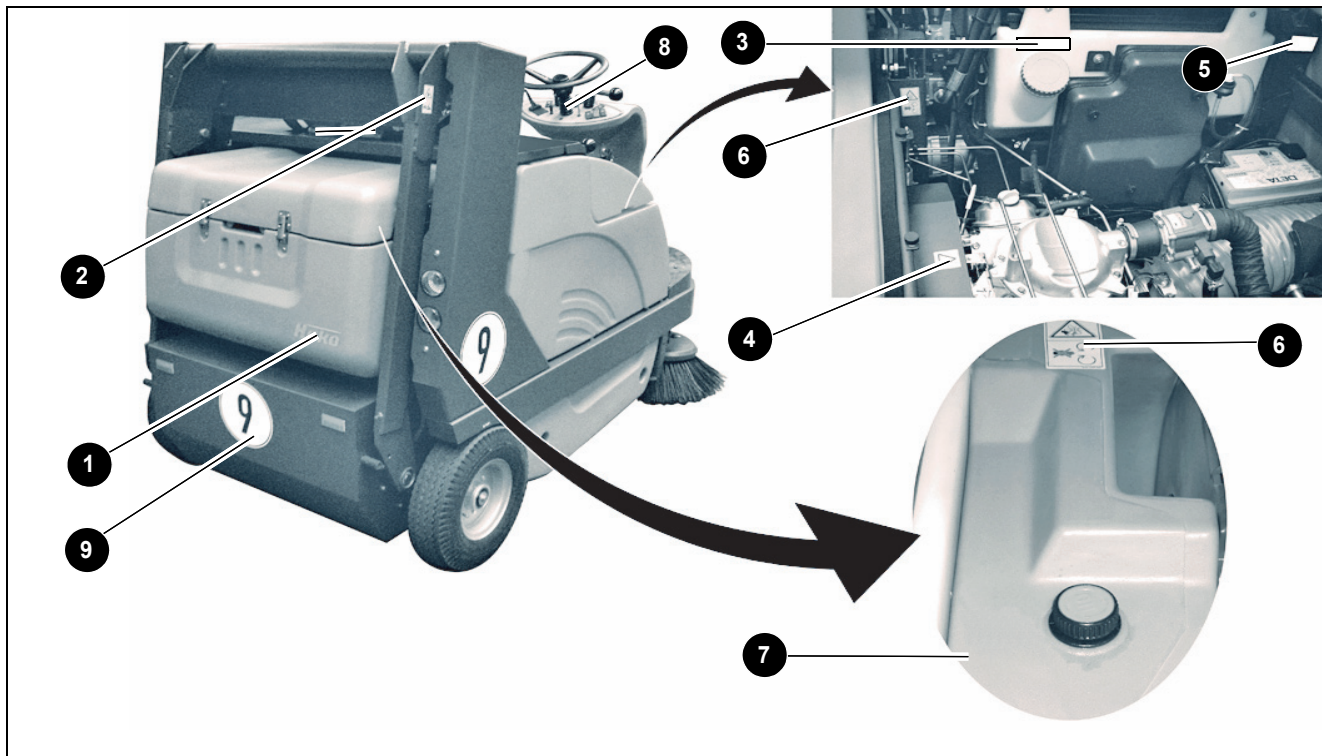

Fig.2

First Operation

2 First Operation

2.1 Instruction

Instruction is required before first operation. First instruction into handling of the machine must be held by a qualified person sent by your local Hako contract dealer. Your Hako dealer will be informed by the manufacturer upon delivery of the machine and will contact you to make a date for instruction.

2.2 Initial charging procedure



Before first operation of the machine, fully charge the battery with an initial charging procedure and comply with the operating instructions of the charger as well as with those of the battery manufacturer. Hako cannot be held liable for damages resulting from an insufficient initial charge.

2.3 Before Putting into Operation

Complete the following inspections before taking the machine into operation: Check the area around the machine for signs of leakage. Hoses, lines and tanks must be free from any leakage or damage.

1. Open seat hood.
2. Check fuel level and refill if required.
3. Check engine oil level.
4. Close seat hood.

2.4 Start Machine



Before starting the machine you are advised to read and comply with the Provisions of Operating from Safety Information chapter!

Before starting the machine, subsequently actuate the following control elements:

1. Set all operating levers and switches to neutral.
2. Secure the vehicle by engaging the parking brake.
3. Turn ignition key to switch on ignition.
4. Sweepmaster P1200 RH:
Actuate choke (with cold engine only).
Sweepmaster D1200 RH:
Preheat until control lamp extinguishes.
5. Continue turning ignition key clockwise to start engine.
- After the motor has started, the en-

gine oil pressure and charge status lamps have to extinguish.



Do not use the Sweepmaster at ambient temperatures of more than 40°C.

Do not start the machine at temperatures of -15°C or less.



Its not possible to start the machine, when the accelerator pedal is linked.



If the starting procedure has to be repeated or if the engine stops, re-starting is possible only after ignition has been turned off. The ignition lock is equipped with a protection to preclude repeated ignition with the engine running.



Interruption of the starting procedure after 10 seconds and brief pause between starting cycles is recommended to save the battery.

6. Run the engine up and press slowly the choke knob (Sweepmaster P1200 RH) down.

First Operation

2.5 Operation

Proceed to the following to set the machine into operation:

1. Check the machine, see paragraph 2.3 - Before Taking into Operation.
2. Start vehicle, see paragraph 2.4.
3. Adjust service speed.



In initial position, vacuuming is activated. Use the operating draw if the collected dirt is wet.

4. Lower sweeper roller and side broom.
5. Release parking brake.
6. Slowly depress drive pedal until desired speed has been attained.
7. Check filling level of the dirt hopper and empty if required.
8. Operate shaking installation regular for cleaning the filter.

2.6 Machine stopping and parking

1. Release drive pedal which returns automatically in neutral position and the machine slows down to standstill.
2. Actuate parking brake.
3. Lift sweeper roller and side broom.
4. Turn engine off.



Slowing down the Sweepmaster is possible by applying opposite forces with the drive pedal or by using the service brake.



When leaving the machine unattended, pull key in order to preclude unauthorized use.

2.7 After work

1. Move the machine to suitable site for cleaning.
2. Stop machine, lift sweeper roller and side boom.
3. Start shaking procedure.
4. Empty dirt hopper, see operation chapter 3.2.2.
5. Clean machine.



Do not clean the electrical parts by means of high-pressure cleaning equipment.

First Operation

2.8 Transport rides and Towing Transport rides

Before transporting the Sweepmaster on other vehicles, engage the parking brake and secure the machine by placing wedges at the wheels and by straps on the tie-down points front (Fig. 3/1) and rear (both sides) (Fig. 3/2).

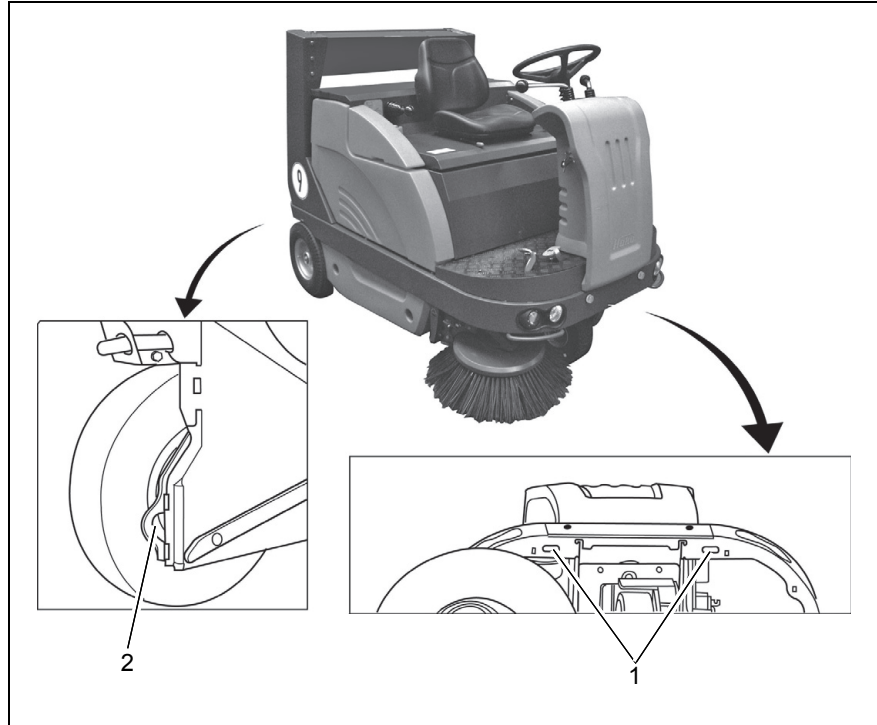

Fig.3

First Operation

Towing

If the Sweepmaster should be moved with engine being off, actuate the bypass valve (Fig. 4/4) as follows.

1. Open seat hood.
2. Loosen wing screw left (Fig. 4/1) and wing screw right (Fig. 4/2) of side covers.
3. Tip front plate (Fig. 4/3) forward.
4. Turn the lever (Fig. 4/4) of the bypass valve anticlockwise approx. to the touch.

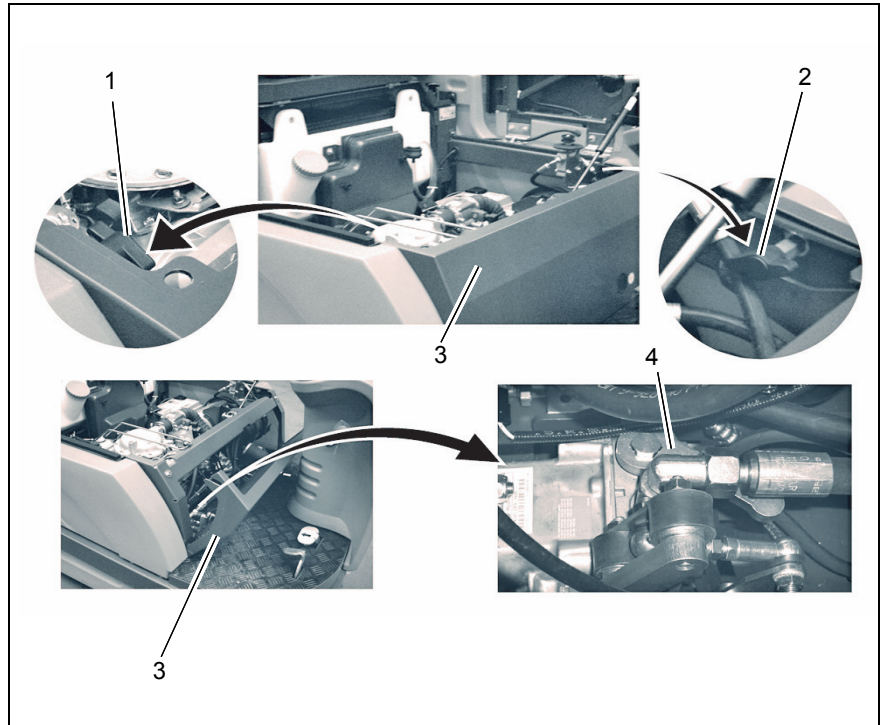

Fig.4

3 Operation

3.1 Working Procedure

General

The Sweepmaster sweeper has been exclusively designed for collecting dry and moist matter from floor surfaces in e.g. factories, storage buildings, parking grounds and pedestrian areas.

Functional Description

The side broom (Fig. 5/1) is used to collect dirt at corners and borders and to enlarge the working width as well as to increase the area performance on large surfaces.

The sweeper roller (Fig. 5/2) casts the dirt overhead into the dirt hopper (Fig. 5/3). The collected fine dust is evacuated by the suction fan and separated by a filter system (Fig. 5/4). The air returned into the environment is clean. Dirt disposal at the Sweepmaster is realized via lift-up disposal (lift-up height > 1420mm) directly into standard waste container.

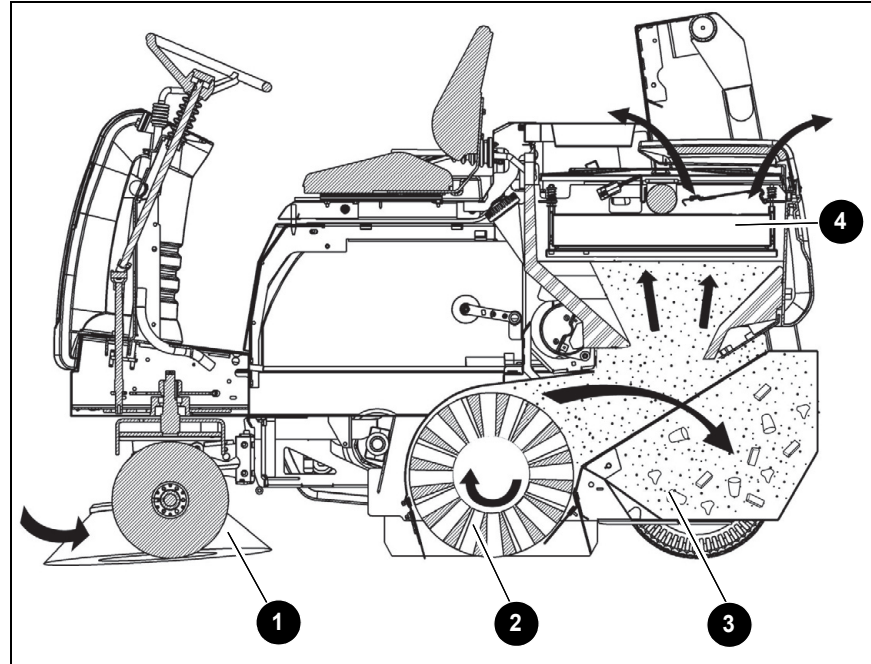

Fig.5

Operation

3.1.1 Sweeper Roller

The sweeper roller (Fig. 5/2) is equipped with 12 rows of bristles arranged in v-shape.

The sweeper roller width amounts to 800 mm and its diameter to 430 mm.

The operator lifts and lowers is by hand lever (Fig. 6/1).

3.1.2 Side Broom

The standard version, the side broom (Fig. 6/2) is located at the front right of the machine. The operator lifts and lowers is by hand lever (Fig. 6/3).

The swinging area of the side broom arm is limited by stops.

For special application, fitting of a second side broom at the left side is possible.

3.1.3 Steering

Steering is effectuated mechanically from steering wheel to front wheel via chain. This chain is to be re-adjusted as required.



Fig.6



Any work at the steering has to be executed by authorized Hako-service-workshop only.

Operation

3.1.4 Filter System Dust Evacuation

The filter system is located in the filter case (Fig. 7/1) above the dirt hopper (Fig. 7/2). The suction fan transports the fine dust raised by the sweeper roller to the plate filter (Fig. 7/3) where it is separated. The fine dust sets at the outside of the filter blades.



In case of heavy dusty sweeping dirt, check and clean the plate filter (Fig. 7/3) at regular intervals.

3.1.5 Shaking System

Due to normal working vibration the set dust from the plate filter (Fig. 7/3) partly falls off into the dirt hopper (Fig. 7/2). To ensure working in a dustfree ambiance, actuate the shaking system regularly, or after request by the control lamp (Fig. 10/5) at the latest.

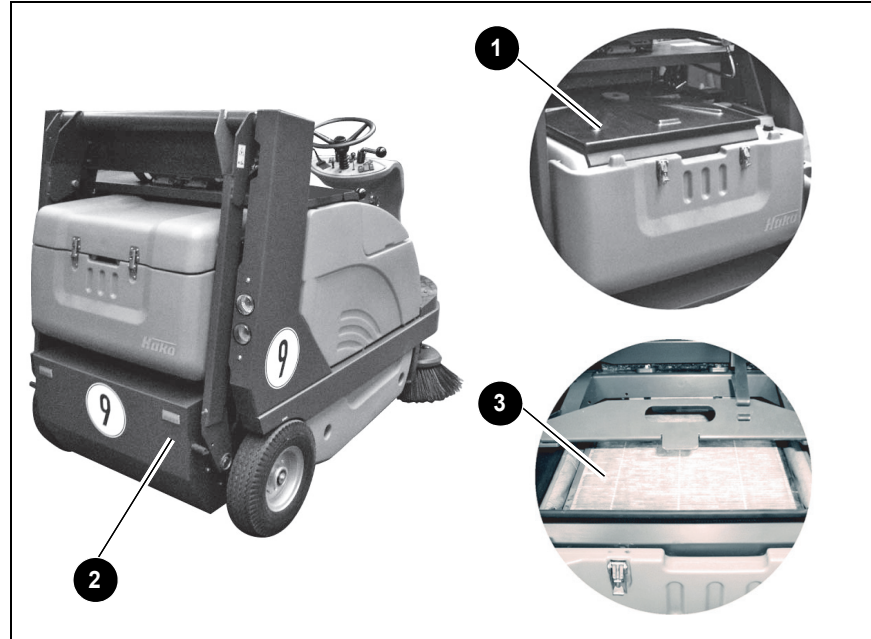

Fig.7

Operation

3.1.6 Brake

The Sweepmaster is equipped with a service brake. This brake has been constructed as shoe brake and equally serves as parking brake. It is located in the rear wheels and is actuated via cables. Two special adjustment screws (Fig. 8/2) are located in front of the chassis, behind the front cover (Fig. 8/1).



Any work at the braking system has to be executed by authorized Hako-service-workshop only.

3.1.7 Travel Drive Assembly

The Sweepmaster are equipped with a hydrostatic drive assembly which is driven by the combustion engine via hydraulic pump.

3.1.8 Hydraulic System

The hydraulic system existing of hydraulic valves, hydraulic pump with hydraulic fluid tank (Fig. 8/3) and serves the operation of the lifted-up disposal and the side broom.

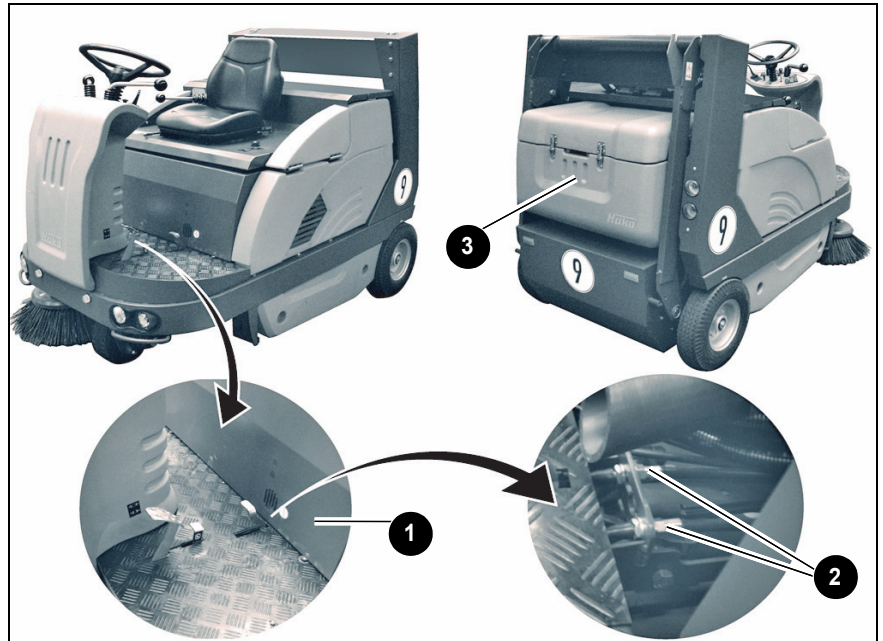

Fig.8

Operation

3.2 Operating Elements

- 1 Actuator for folding apron
- 2 Service brake lock
- 3 Service brake / parking brake pedal
- 4 Drive pedal, reverse
- 5 Drive pedal, forward
- 6 Control panel
- 7 Seat adjustment
- 8 Lever for dirt hopper (lifting-lowering-swinging)

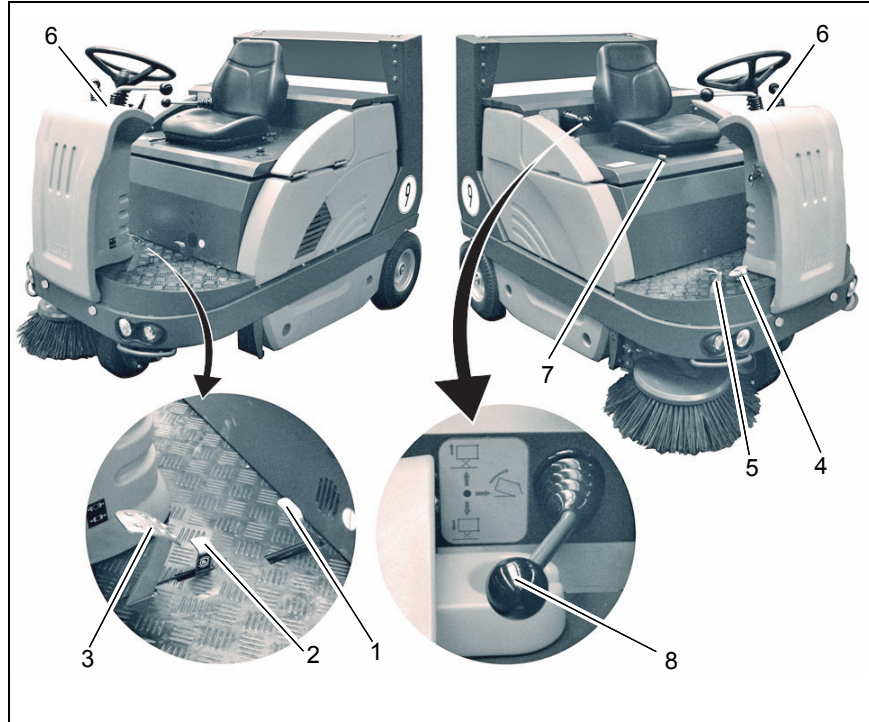

Fig.9

Operation

Actuator for folding apron (Fig. 9/1)

To open and close the folding apron for collecting coarse dirt during sweeping drive.

Service brake / parking brake lock (Fig. 9/2)

To lock the service brake / parking brake. Operate pedal and fix with lock. The service brake is working then as parking brake. The lock released by pushing service brake pedal (Fig. 9/3).

Service brake / parking brake pedal (Fig. 9/3)

Serves for operating the service brake on the rear wheels. Simultaneously actuate service and parking brake before leaving the machine.

Drive pedal, forward (Fig. 9/5)

To change direction to forward ride with continuous regulation of riding speed at the same time. If the driver releases the pedal it returns to initial position and the machine slows down to standstill.

Drive pedal, reverse (Fig. 9/4)

To change direction to reverse ride with continuous regulation of riding speed at the same time. If the driver releases the pedal it returns to initial position and the machine slows down to standstill.

Control panel (Fig. 9/6)

Refer to chapter „control Panel“.

Seat adjustment (Fig. 9/7)

To adjust the seat position to drivers of different height. Adjust the seat so as to allow the driver being comfortably seated and attaining all elements required for operation.

- Adjust seat lengthwise:
push lever slightly to the right and displace seat forwards or backwards to the required position.
Then let the lever catch again.

Lever for dirt hopper (Fig. 9/8) (lifting-lowering-swinging)

Lever for lifting-lowering-swinging the dirt hopper.

For lifting and lowering pull simultaneously lever for release of lifted-up disposal function (Fig. 10/1).

Swinging follows without operating of the lever (Fig. 10/1).

Operation

3.2.1 Control Panel

- 1 Sweeper roller lever and release of lifted-up disposal function
 - 2 Side broom lever or rather for side broom and sweeper roller
 - 3 Engine speed regulation knob
 - 4 Suction fan / shaking system knob
 - 5 Control lamp, shaking system
 - 6 Control lamp, direction indicator (Option)
 - 7 Hourmeter
 - 8 Control lamp, parking brake
 - 9 Battery charge status indicator
 - 10 Horn
 - 11 Ignition switch
 - 12 Indicator lever (Option)
 - 13 Lighting (Option)
 - 14 Warning light (Option)
 - 15 Rotating beacon (Option)
 - 16 Side broom left (Option)
 - 17 Control lamp, engine oil pressure
 - 18 Choke flap knob
- Sweepmaster P1200 RH**
- 19 Control lamp engine oil pressure and water temperature
 - 20 Control lamp, preheat
- Sweepmaster D1200 RH**

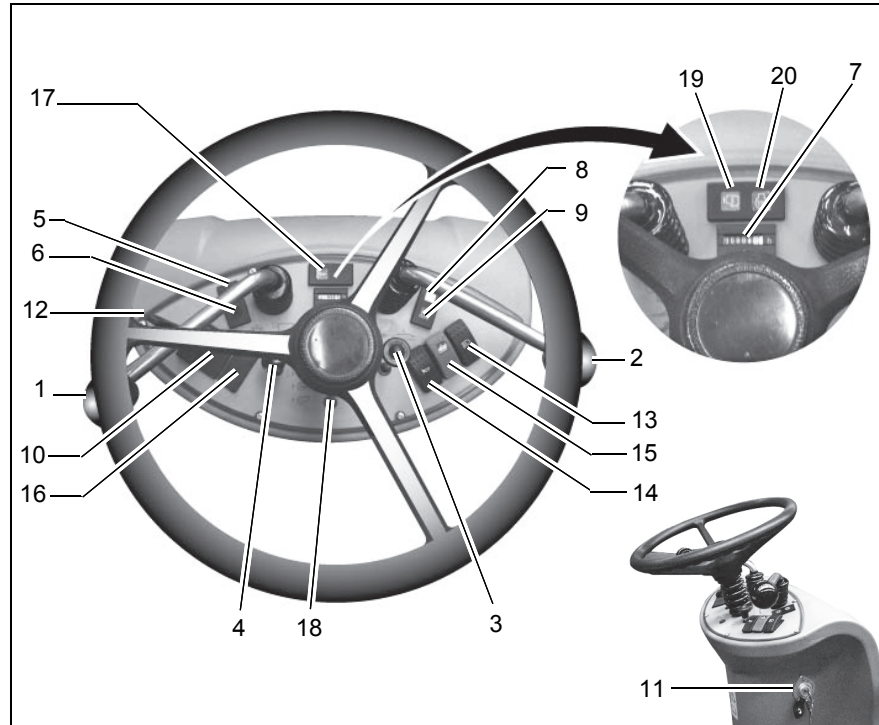
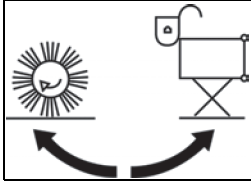

Fig.10

Operation



Sweeper roller lever and lifted-up disposal (Fig. 10/1)

Two-Hand-Operation.

For lifting, lowering, swinging, to switch on and off the sweeper roller and to release of lifted-up disposal.

- Sweeper roller lowering and switch on = push lever
- Sweeper roller lifting and switch off = pull in middle position
- Release of lifted-up disposal function = pull lever

(see chapter „Emptying of the Dirt Hopper“).



Lifting and turn off the sweeper roller, if the lever for the right side broom is in lifting position.



Side broom lever (Fig. 10/2)

To lift and lower the side broom or lower and turn on the side broom and sweeper roller in one process (Fig. 10/1).

- Lower side broom = push lever.
- Lift side broom = pull lever.

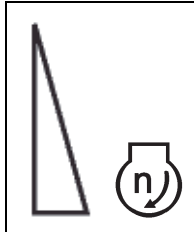

Engine speed regulation knob (Fig. 10/3)

To adjust the engine speed. Neutral speed is attained by pulling the knob up.

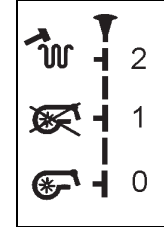

Suction fan / shaking system (Fig. 10/4)

Knob position

(from bottom to top):

- 0 Activated vacuuming function
- 1 Deactivated vacuuming function
- 2 Shaking system ON (pull knob to stop and then release)

If the yellow control lamp (Fig. 10/5) lights by ignition or with the engine running, actuate the shaking system (position 2).

In this position, the shaking system is operable and proceeds to jolting in 7 repeated intervals.

Operation



After jolting, the knob is to be kept in position 1 for about 25 seconds.



Control lamp, shaking system (Fig. 10/5)

Proceed to jolting of the filter system upon lighting of this control lamp by actuating the knob (Fig. 10/4) in position 2.



The control lamp flashes during the shaking procedure and extinguishes after filter has been cleaned. Jolting is effectuated in 7 intervals.

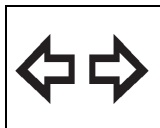

Control lamp, direction indicator (Option) (Fig. 10/6)

Indicate, if using the indicator lever, the direction.

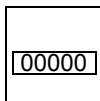

Houmeter (Fig. 10/7)

Indicates the operating hours. the counter works only if the driver is seated and the ignition is ON.



Control lamp, parking brake (Fig. 10/8)

Lights upon actuation of the parking brake. Extinguishes upon release of the parking brake.



Battery charge status indicator (Fig. 10/9)

Lights upon actuation of the ignition switch and has to extinguish as the engine fires.



Horn (Fig. 10/10)

An acoustic signal sounds upon actuation of this button.

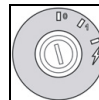

Ignition switch (Fig. 10/11)

To switch ignition on and off, to start and stop engine and to secure it against unauthorised use.

Operation



For safety reasons, the Sweepmaster has been equipped with a seat contact switch.

Starting the engine is possible only after the driver has taken place on the seat. If seat contact is interrupted while the engine is running, the combustion engine of the Sweepmaster has to be re-started.



The Sweepmaster can not started, when the accelerator pedal is linked.

Indicator lever (Option) (Fig. 10/12)

Indicate changing of direction

- Lever down = to left.
- Lever up = to right.



Lighting (Option) (Fig. 10/13)

To switch the driving headlight ON/OFF.



Warning light (Option) (Fig. 10/14)

Use this switch by a technical defect, if it is impossible to move the machine. Lighting flashes ON/OFF.



Rotating beacon (Option) (Fig. 10/15)

To switch the rotating beacon ON/OFF.



Side broom left (Option) (Fig. 10/16)

For special application, fitting of a second side broom at the left side is possible.

- Switch actuate = side broom lowering and turning on.
- Switch not actuate = side broom lifting and is laying up.



Control lamp, engine oil pressure (Sweepmaster P1200 RH only) (Fig. 10/17)

Lights upon, if too few engine oil in the engine oil tank. Stop the machine and refill engine oil.

If control lamp continues lighting please inform the Hako-Service department.

Operation

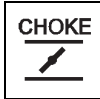

Choke flap knob (Sweepmaster P1200 RH only) (Fig. 10/18)

To actuate the chke flap (cold start).

- Knob down = choke not actuated.
- Knob pulled up = choke actuated for cold start.



Control lamp, preheat (Sweepmaster D1200 RH only) (Fig. 10/20)

Lights upon by switch on ignition. Start the machine when control lamp extinguish.

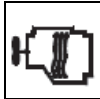

Control lamp engine oil pressure and water temperature (Sweepmaster D1200 RH only) (Fig. 10/19)

The contrl lamp lights upon occurrence of an error at the engine or the controller. If control lamp continues lighting please inform the Hako Service department.

Operation

3.2.2 Emptying of the Dirt Hopper

Proceed to emptying of the dirt hopper as follows:

- Lift and switch off side broom and sweeper roller.
- Proceed to shaking of the filter system.
- Lift dirt hopper as follows:
Pull lever for dirt hopper (Fig. 11/1) upwards and simultaneously pull the lever for sweeper roller and release for lifted-up disposal (Fig. 11/2) in arrow direction.
- Bring dirt hopper for disposal in suitable height position.
- Back the Sweepmaster until the dirt hopper is positioned above the container.
- Pull lever for dirt hopper (Fig. 11/1) in arrow direction, dirt hopper is swinging in emptying position.
- Forward the Sweepmaster after complete emptying.



Caution by driving away, if dirt hopper is towering in the container:
Hazard of damaging!

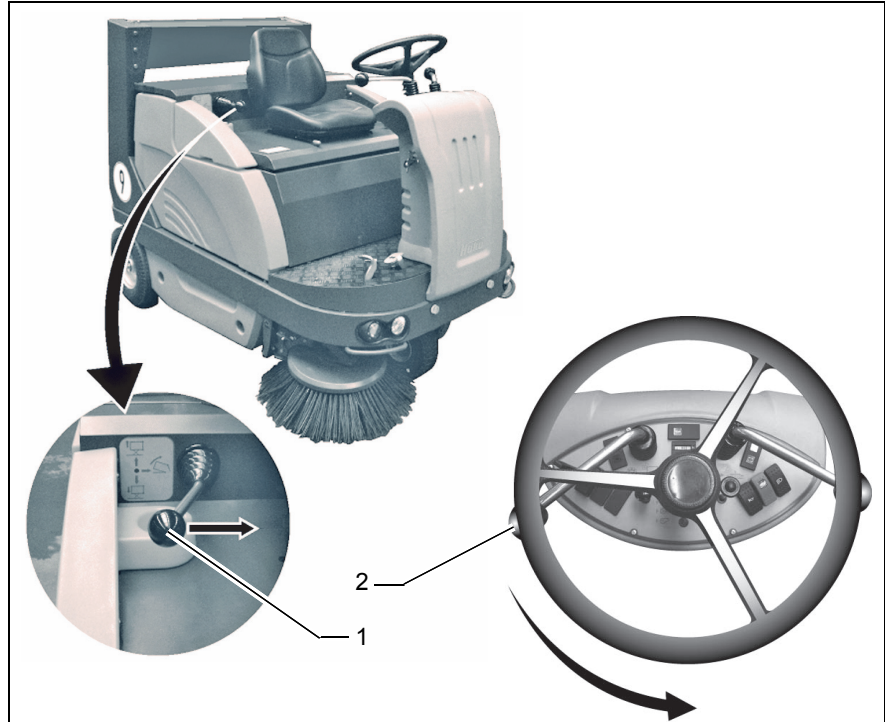

Fig.11

Operation

- Lower dirt hopper as follows:
Pull lever for dirt hopper (Fig. 11/1) down and simultaneously pull the lever for sweeper roller and release for lifted-up disposal (Fig. 11/2) in arrow direction.
- The dirt hopper is swinging automatically in starting position by lowering.
- Dirt hopper is again in working position.



The operation of lifted-up disposal function is blocked as long as sweeping function is ON.



Do not switch on sweeper roller when dirt hopper lifting out.



Riding with the lifted dirt hopper reduces stability of the machine significantly. For this reason, do not lift the dirt hopper but just before emptying. Before lifting the dirt hopper, the operator has to make sure that no persons or objects are behind or next to the machine. Stop the machine on level

ground before lifting the dirt hopper.



When the dirt hopper is lifted, the operator has to ride the machine slowly.



Keep clear of the hazard zone! Pinching and shearing hazard. Provide for required safe distance before lifting or lowering the dirt hopper



The dirt hopper is approved only for max. filling of 130 litres but not more than a weight of 220 kg.



Do not move the machine during the lifting procedure.



Clean the dirt hopper in regular intervals.

Technical Data

4 Technical Data

Sweepmaster		
Dimensions and weights		
Length with side broom	mm	1998
Width without side broom	mm	1142
Width with 1 side broom	mm	1142
Width with 2 side brooms	mm	1142
Height above driver's seat	mm	1520
Dead weight	kg	V: 763 / D: 776
Admissible total weight	kg	1322
Driving and sweeping performance		
Forward speed	km/h	0-9
Reverse speed	km/h	0-4
Sweeping speed up to (4 km/h recommended)	km/h	9,0
Sweeping track w/o/with 1 side broom	mm	800 / 1150
Sweeping track with 2 side brooms	mm	1470
Theoretical sweep. perf. with 1 or 2 side brooms	m ² / h	10300/13200
Theoretical sweep. perf. without side broom	m ² / h	7200
Gradability, max.	%	18

Technical Data

Sweepmaster		
Filter system		
Filtering surface	m ²	5,0
Plate filter	peaces	1
Sweeper roller		
Length / diameter	mm	800 / 430
Wearing limit	mm	350
Speed	1/min	500+/-20
Sweeping track	mm	70+10
Quantity of bristle rows		12 v-shaped
Serial bristling		PA
Ground clearance of sealing		
Sealing strips, left / right / rear	mm	1 / 1 / 4
Sealing strip, front		lying on the bottom
Side brooms		
Diameter	mm	600
Speed	1/min	85+/-4
Serial bristling		PA

Technical Data

Sweepmaster		
Dirt hopper		
Hopper capacity	litre	130
Drive wheels		
wheel front, solid rubber tyres		4.00-4
Wheels rear		4.00-8
Inflation pressure	bar	6
Solid rubber tyres (rear)		4.00-8 (Option)
Hydraulic system Travel drive assembly		
Hydraulic fluid, e.g. Mobiloil		DTE 15 M (or an equivalent oil)
Hydraulic tank, capacity	litre	22
Fluid filter cartridge	order-no.	CS-050-P-10-A
Electric system		
Starter battery	V / Ah	12/60
Generator	A	55
Type of protection		IPX3

Technical Data

Sweepmaster		P1200 RH	D1200 RH
Engine			
Manufacturer		Briggs & Stratton	Kubota
Type		Vanguard V-Twin	Z482-E4B
Working process/no. of cylinders		4-Takt / 2 Zyl.	4-Takt / 2 Zyl.
Piston capacity	cm ³	480	479
Performance at 2550 rpm	KW	8.2	8.0
Service speed (with sweeper roller, side broom and suction fan being on)	rpm	2550+50	2450 +50
Fuel tank capacity	litre	25 (unleaded)	25 (diesel low-sulfur)
Fuel consumption	litre / h	2,5	1,24
Engine oil / filling	type / litre	15W-40 / 1,5	15W-40 / 2,0
Spark plug		Champion XC 92 YC	
Air cleaner		Mann & Hummel 44 100 92 911	Mann & Hummel 44 100 92 911

Technical Data

Sweepmaster		P1200 RH	D1200 RH
Noise emission value			
The sound pressure level (L_{pA}) (at the ear of the operator) measured according to DIN IEC 60335-2-72 under normal working conditions:	dB (A)	78	79
Measurement inaccuracy (K_{pA}):	dB (A)	2	2
Sound power level (L_{WA_d}) measured according to DIN EN 60335-2-72 under maximum working conditions:	dB (A)	94	96
Sound power level (L_{WA_d}) measured according to 2000/14/EG under maximum working conditions:	dB (A)	94	96
Vibration			
The weighted effective value of acceleration, measured in accordance with ISO 5349-1, to which the upper parts of the body (hand-arm) are exposed under normal working conditions:	m/s^2	<2,5	<2,5
The weighted effective value of acceleration, measured in accordance with ISO 2631-1, to which the body (feet-seat) is exposed under normal working conditions:	m/s^2	<0,5	<0,5

5 Maintenance and Care

General



Before proceeding to maintenance and care work you are advised to read and comply with the Safety Information chapter!

Compliance with the recommended maintenance works will give you the certitude of always having a reliable machine at disposition.

Daily or weekly maintenance and repair works may be executed by the driver/operator having been trained accordingly. Further Hako system maintenance works, see Service manual, have to be executed by qualified personnel only. Please contact your local Hako Service Centre or Hako contract dealer. We cannot be held liable for damages resulting from non-compliance with these instructions.

Please indicate the machine's serial number with any enquiry or spare part order, see paragraph 1.7 - Nameplate.

Maintenance and Care

5.1 Maintenance Schedule

Hako-System Mainten. Customer

The following maintenance works are to be performed by the customer.

Discription of task	Interval
	daily
Check engine oil level and refill if required	o
Check fuel level and refill if required	o
Check the radiator fins and clean if required	o
Check dirt hopper (dustbin), and empty if required	o
Operate shaking system	o
Test drive and function test	o

Maintenance and Care

Hako-System Maintenance Customer

The following maintenance works are to be performed by the customer.

Discription of task	Interval
	weekly
Check engine air cleaner for soiling and clean if required (tap, do not use compressed air), replace air cleaner insert if required	o
Visual check of engine for oil leakage, refill if required	o
Dirt hopper: Check sealing and replace if required	o
Check sweeper roller for wearing or foreign particles, re-adjust or replace if required	o
Check electrical system	o
Check inflation pressure	o
Check hydraulic fluid level, refill if required	o
Check side broom for wearing, re-adjust and replace if required	o
Check folding apron for wearing and damaging, re-adjust and replace if required	o
Visual check of engine and hydrailic system for oil leakage	o
Clean machine	o
Test drive and function test	o

Maintenance and Care

5.2 Mount/Dismount Sweeper Roller

The sweeper roller is accessible from the left side of the machine and is to be dismantled as follows:

1. Lower sweeper roller
2. Pull ignition key and protect by engaging parking brake.
3. Open locks (Fig. 12/1) by enclosed square spanner (turn counter-clockwise).
4. Remove cover (Fig. 12/2).
5. Loosen star-shaped knob (Fig. 12/3) and remove.
6. Remove sweeper roller seating (Fig. 12/4).
7. Turn handle (Fig. 12/5) upwards and unlock.
8. Remove plate with sealing strip (Fig. 12/6).
9. Remove sweeper roller (Fig. 12/7) by pulling.

For mounting the sweeper roller proceed in inverse order.

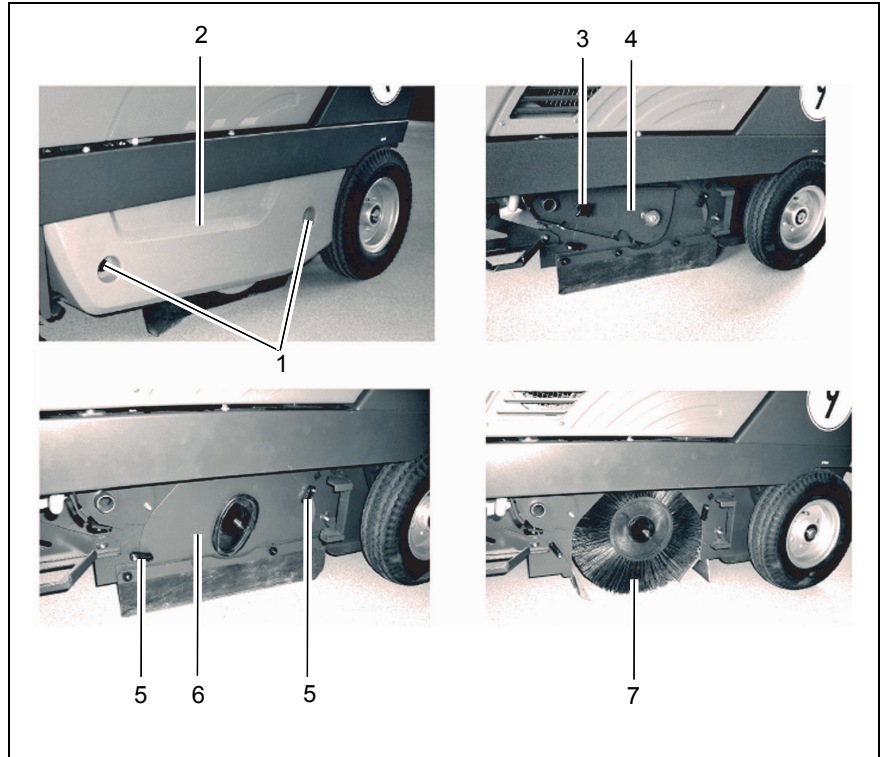

Fig.12

Maintenance and Care

5.3 Adjust Sweeping Track

An adjustment device allows adaption to different sweeping conditions. The sweeper roller has to be adjusted for normal use and with regard to a low degree of wearing as described in the following.

Check the sweeper adjustment on level ground as follows:



Before checking:
Mark level surface for checking sweeper adjustment by chalk (1000 x 300 mm).
Drive sweeping roller over underline floorspace.



Check inflation pressure of tyres (6bar).
Air tyres only.

1. Secure machine by engaging parking brake.
2. Lower sweeper roller and let it run dry.
3. Lift sweeper roller and forward the Sweepmaster a bit.
With the correct sweeper adjustment the parallel sweeping marks have to be appear on the floor (sweeping track).

The sweeping track width is to be 70 mm with the Sweepmaster.

The sweeping track width can be adjusted at the star-shaped knob (Fig. 13/1) as follows:

1. Stop engine and pull key.
2. Engage parking brake.
3. Open seat hood.
4. Turn star-shaped knob (Fig. 13/1) to the left = wider sweeping tack to the right = smaller sweeping track (Sweeper adjustment sticker (Fig. 13/2))

5. Check sweeping track



With one full turn of the knob, the track widens or broadens by approx. 10mm.



When exceeding the sweeping tack width the sweeper roller wearing increases as well as the load of the drive.

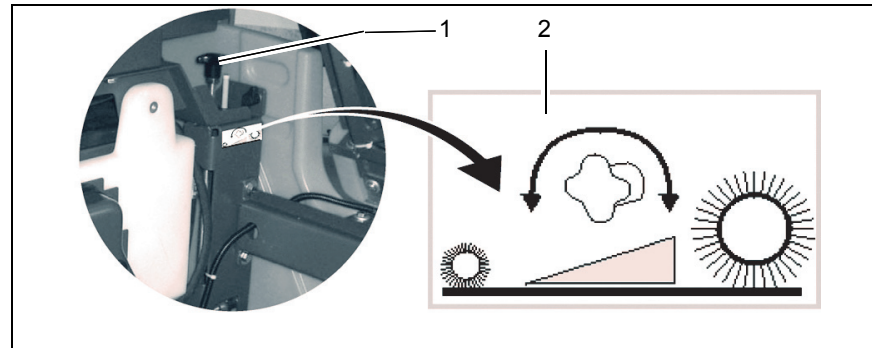

Fig.13

Maintenance and Care

5.4 Sealing Strips for Broom Compartment

In order to assure good function of the sweeper, a perfect condition of the sealing strips is required, especially in order to attain the prescribed low pressure in the broom compartment, a clean sweeping result and the less possible wear of the sealing strips.

Check the sealing strips of the broom compartment for wearing and damages in regular intervals.

Replace defective sealing strips.

The ground clearance of the lateral and rear sealing strips is adjustable (oblong holes in the sealing strips).

Ground clearance:

sides approx. 1mm

rear approx. 4mm

Proceed to adjustment with an inflation pressure of the pneumatic tyres of 6 bar. Height of the front sealing strip (folding apron) cannot be adjusted. Being dragged, it has contact with the floor.

5.5 Replace Side Broom

The side broom is located at the front right of the machine (standard version). Use the lever (chapter 3.2.1, Fig. 10/2) to lift and lower the side broom.

The swinging area of the side broom is limited by stop screws.

The side broom is driven by hydraulic engine.

Fitting of a second side broom (left side) for specific appliances is possible.

Proceed as follows for dismantling of the side broom:

1. Turn engine off and pull key.
2. Secure machine by engaging parking brake.
3. Side broom lifted.
4. Loosen hexagonal nut (Fig. 14/1) below the side broom.
5. Remove side broom.

Proceed in inverse order for mounting of the side broom.

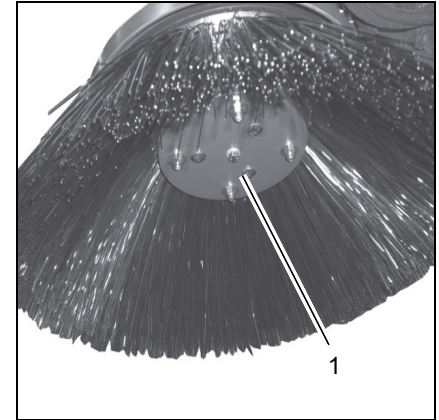

Fig.14



Check for correct mounting.

Maintenance and Care

5.6 Dismount Plate Filter

Proceed as follows for dismounting of the plate filter:

1. Turn engine off and pull key.
2. Secure machine by engaging parking brake.
3. Open quick-release locks (Fig. 15/1) and remove cover (Fig. 15/2).
4. Remove cover (Fig. 15/3) of the filter installation.
5. Loosen wing screws, four pieces, (Fig. 15/4) and remove.
6. Fold back frame (Fig. 15/5) and hook frame (Fig. 15/5) at indicated position by rubber fastening (Fig. 15/6).
7. Remove plate filter (Fig. 15/7).

For mounting of plate filter proceed in inverse order.



Clean filter area.

Check plate filter of damaging. Watch for direction of the air on the plate filter.

Check for correct fit of the plate filter in the machine frame.

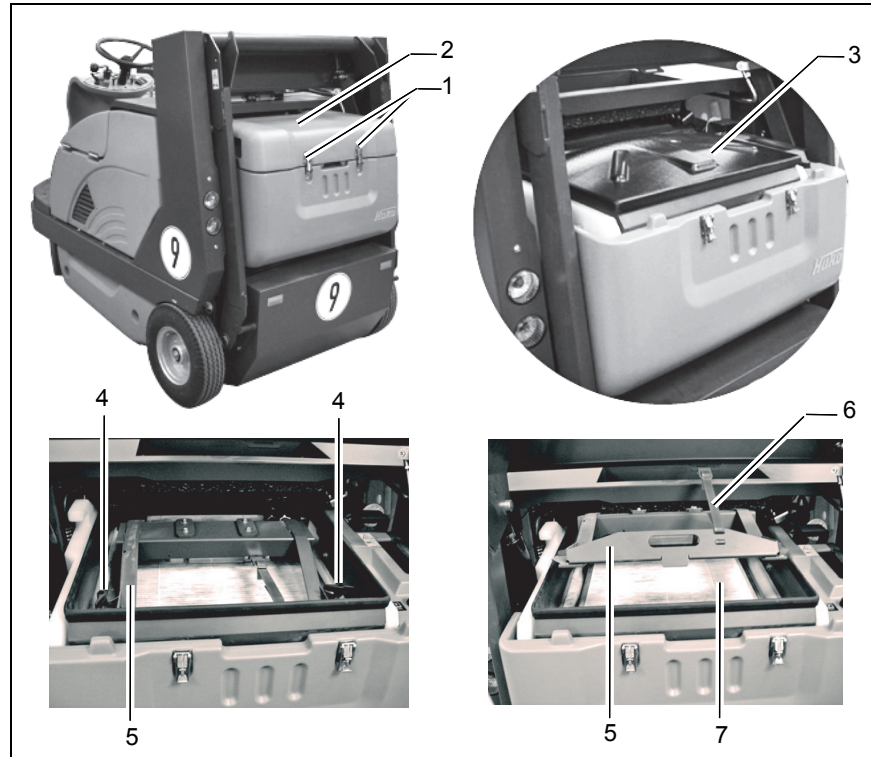

Fig.15

Maintenance and Care

5.7 Basic Cleaning of Plate Filter

Hold the plate filter (Fig. 16/1) in vertical position and drop it from a height of approx. 1m to the even floor as represented in (Fig. 16/).



The soiled side of the plate filter points to the bottom.

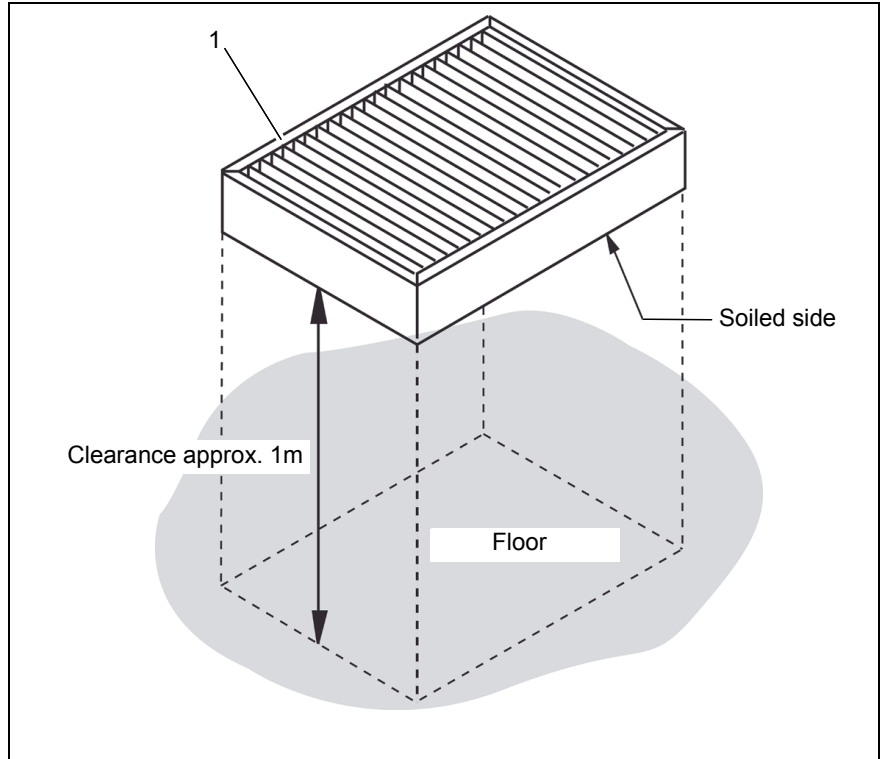

Fig.16

Maintenance and Care

5.8 Engine

General

Maintenance work is to execute at regular intervals. Find the details described in the following.



All repair work on the motor must only be carried out by authorised workshops!



Before cleaning or maintaining the Sweepmaster as well as before replacing parts, turn the engine off and pull the ignition key.

Do not touch any parts such as engine block, cooling system and exhaust system during operation and for some time after. Allow the engine to cool down.

Use appropriate tools for maintenance, service, setting etc. As far as aspect of safety are concerned, spare parts will have to be at least of the same quality as the genuine spare parts.

5.8.1 Checking the supply

1. Switch the engine off and pull out the ignition key.
2. Hold the machine with the parking brake. Allow the engine to cool down.
3. Open the seat hood.
4. Check fuel supply at the display (Fig. 17/1), top up fuel if necessary. Remove the cap to do this (Fig. 17/2).



Extreme caution is required when handling fuel - high risk of fire! Never refuel close to naked flames or ignitable sparks! Do not smoke during fuelling! Switch off the engine, remove the ignition key and engage the parking brake before fuelling. Never refuel in enclosed spaces! Wipe away any spilt fuel immediately!



Fig.17

Maintenance and Care

5.8.2 Check Engine Oil Level



Position the machine on level ground before checking the engine oil level as follows:

1. Turn engine off and pull key.
2. Secure machine by engaging parking brake. Allow the engine to cool down.
3. Open seat hood.
4. Pull plug (Fig. 18/1) with dipstick.
5. Pull dipstick(Fig. 18/1).
6. Wipe dipstick (Fig. 18/1) and push into opening until stop and pull it again.
7. Oil level has to be mark between minimum an maximum (Fig. 18/2), refill engine oil if required.
8. Re-insert dipstick(Fig. 18/1).

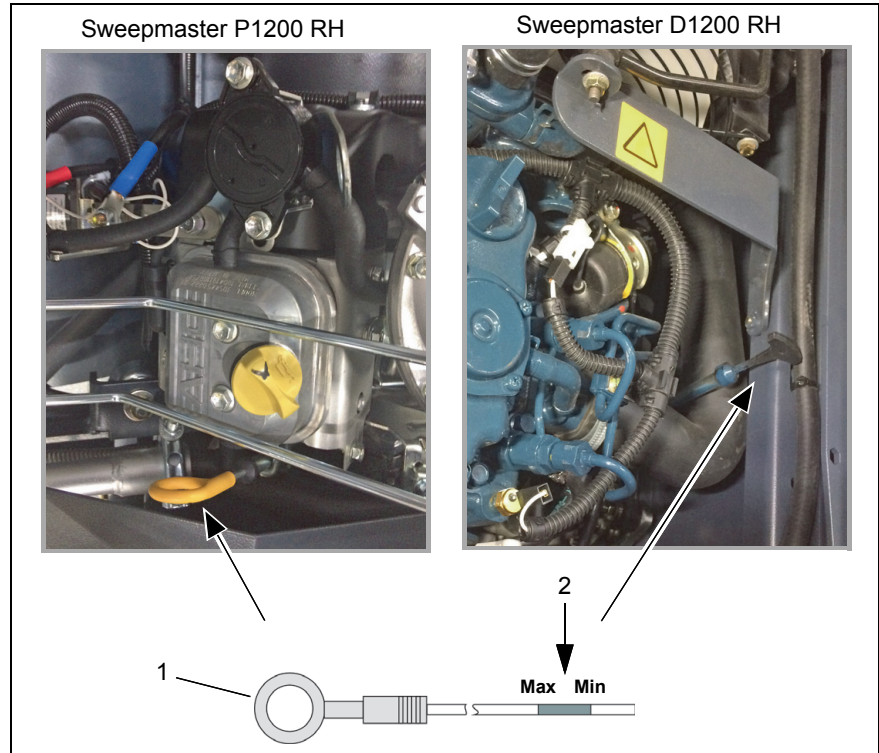

Fig.18

Maintenance and Care

5.8.3 Cleaning the radiator

The radiator is in the engine compartment. Check the radiator fins daily and clean if required.



Risk of injury due to rotating parts! Switch the engine off and pull out the ignition key.

1. Switch the engine off and pull out the ignition key.
2. Hold the machine with the parking brake. Allow the engine to cool down.
3. Open the seat hood and pull out the radiator cover (Fig. 19/1) from above.
4. Check the radiator fins (Fig. 19/2) for contamination and clean as required with compressed air or a water jet.

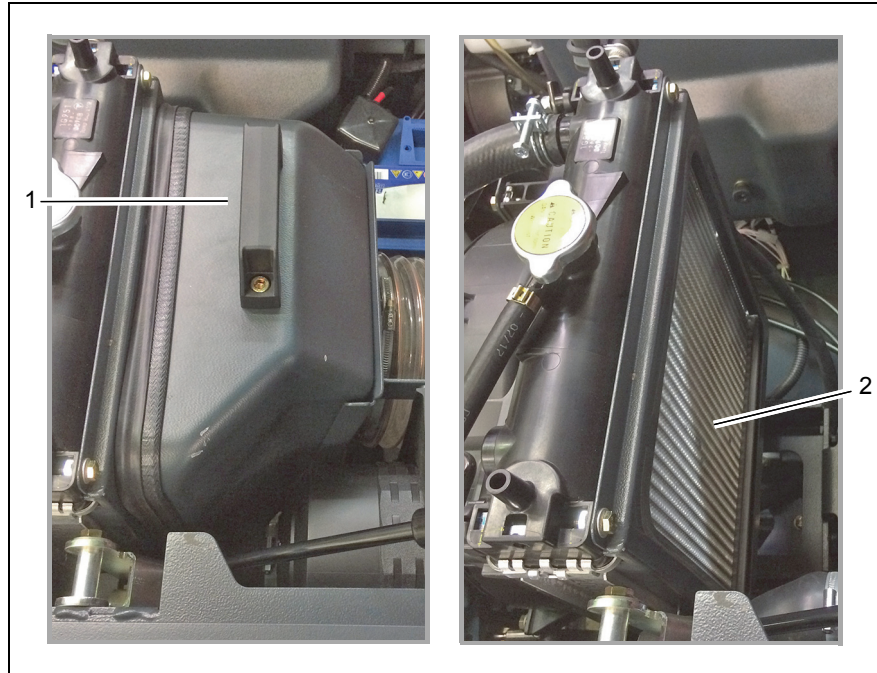

Fig.19

Maintenance and Care

5.8.4 Checking the coolant level

Check the coolant level in the expansion tank daily and top up as required.



Risk of scalding due to hot coolant! The cooling system is under pressure. Caution! Parts of the engine may still be hot.

1. Turn off the engine, remove the ignition key and secure the machine with the parking brake. Allow the engine to cool down.
2. Open the seat hood.
3. Check the coolant level. With the engine cooled down, coolant must be visible between the MIN and MAX mark of the expansion tank (Fig. 20/1).
4. Unscrew the cap carefully step by step from the expansion tank. The coolant additive must be at least 40% and may be a maximum of 60%. Never drive without coolant additive!
5. Check the coolant level, refill once again if necessary. Close the cap again.

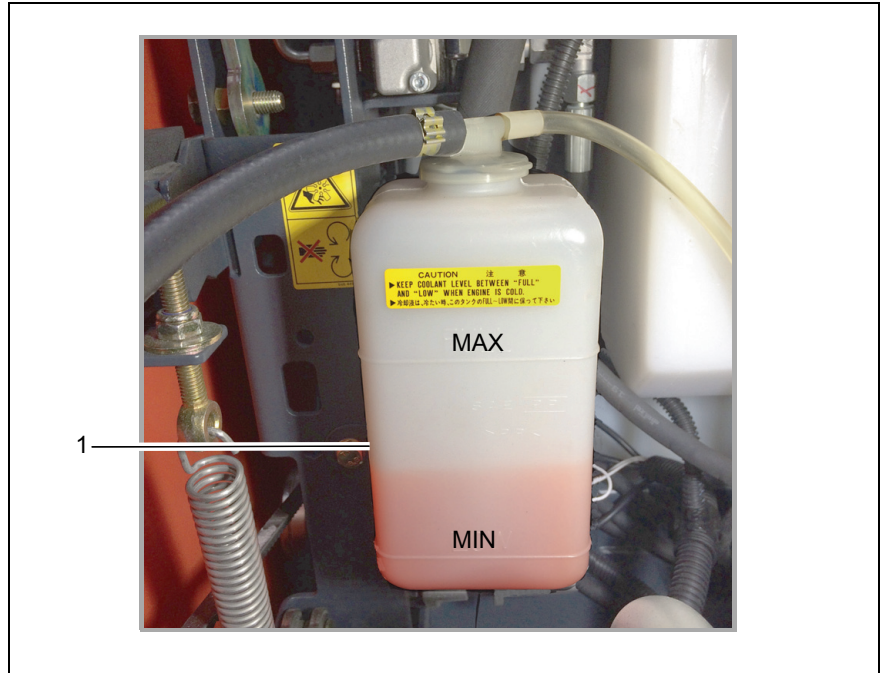

Fig.20

Maintenance and Care

5.8.5 Air Cleaner

The air cleaner is located in the engine compartment. Clean the air filter weekly and change them after 125 hours of operation.



A soiled filtering insert may lead to reduced performance and heavy smoking of the engine. Never let the engine run without filtering insert.

1. Turn engine off and pull key.
2. Secure machine by engaging parking brake. Allow the engine to cool down.
3. Open seat hood, loosen and remove the wing screws of the left side cover.
4. Remove side cover.
5. Remove lock cap (Fig. 21/1) and filter (Fig. 21/2).
6. Proceed to dry cleaning of the air filter or replace if required.

For mounting of air filter proceed in inverse order.

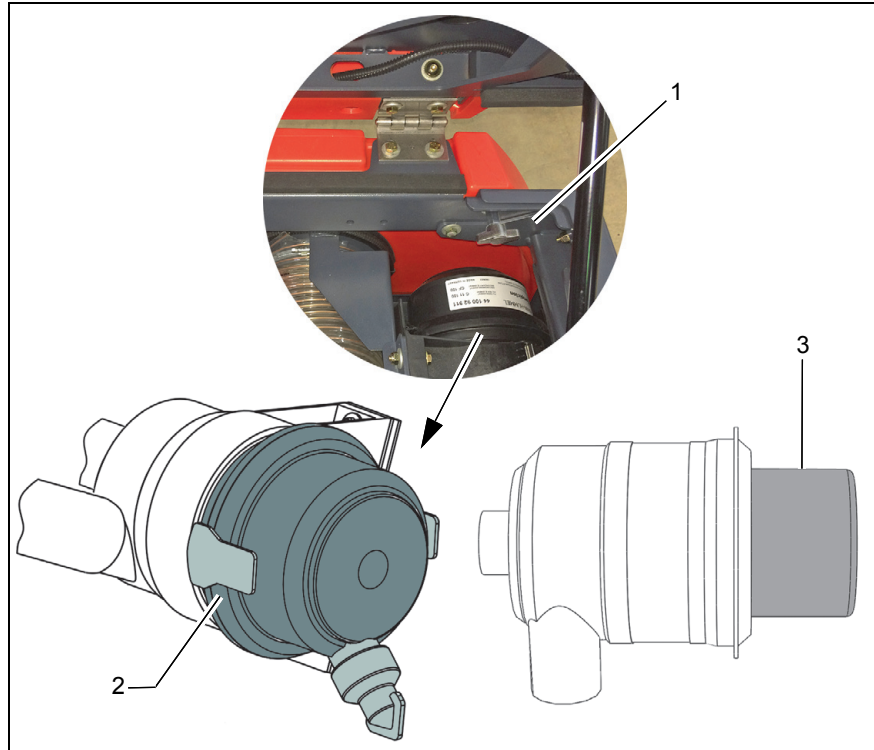

Fig.21

Maintenance and Care

5.9 Hydraulic System

The hydraulic units are aoi- and maintenance-free. The hydraulic oil and filter concerned my maintenance work only. Premature failure can be prevented by regular inspection and periodical maintenance according to maintenance schedule.



We recommend having all other works at the hydraulic system done by a authorized Hako-service-workshop.

Hydraulic oil

The machine is filled with one of the following hydraulic oils in the factory:

- Mobil DTE 10 Excel 46 (HVLP, zinc-free)
- TOTAL EQUIVIS AF 46 (HVLP, zinc-free)
- Panolin HLP Synth 46 (HEES, bio-degradable)

The designation of the hydraulic oil used in your machine can be found on the adhesive label on the hydraulic tank, see figure.

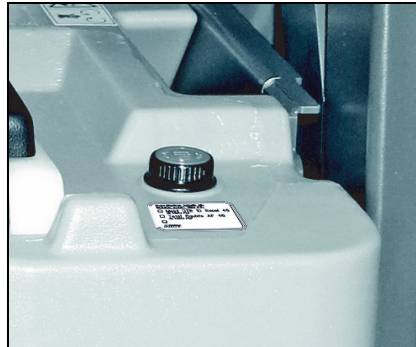

Fig.22

Mixing different hydraulic oils is not permitted. This may reduce the efficiency and reliability of your machine. Hydraulic components could be damaged. Always use the identical oil for topping up. If all of the hydraulic oil is replaced, the usual procedures must be noted (e.g. flush several times, maximum residual hydraulic oil content: 2%). The above-mentioned hydraulic oils are coordinated with the climatic conditions in central Europe. If the machine is used under other climatic conditions, hydraulic oil in a different viscosity class must be used if necessary. Contact Hako if you wish to use a different hydraulic oil.

Maintenance and Care

5.9.1 Check Hydraulic Fluid Level

1. Turn engine off and pull key.
2. Secure machine by engaging parking brake. Allow the engine to cool down.
3. Open quick-release locks (Fig. 23/1) and remove cover (Fig. 23/2)
4. Clean the area of the dipstick (Fig. 23/3).
5. Pull dipstick (Fig. 23/3).
6. Wipe dipstick by means of cloth.
7. Put in dipstick until stop.
8. Pull dipstick (Fig. 23/3) and check the hydraulic fluid level, refill if required.

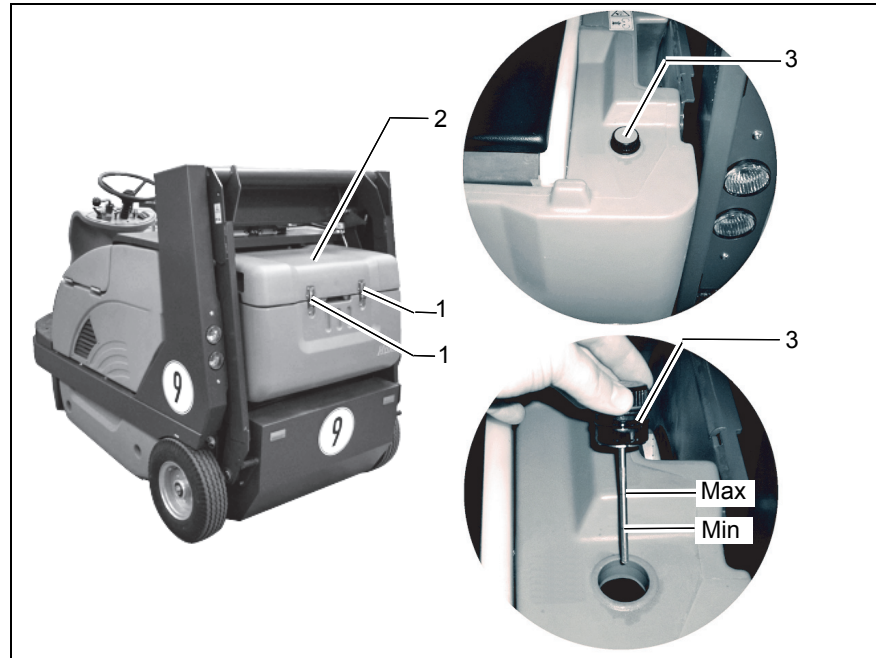

Fig.23

Maintenance and Care

5.9.2 Refill Hydraulic Fluid

1. Unscrew cap with dipstick (Fig. 24/1) and check hydraulic fluid level, see paragraph 5.9.1.
2. Use appropriate oil-resistant recipient with mouth or funnel for refilling.
3. Proceed to check of fluid level after refilling.
4. The hydraulic fluid level must not fall below the minimum. It should read between the minimum and the maximum (Fig. 24/2).

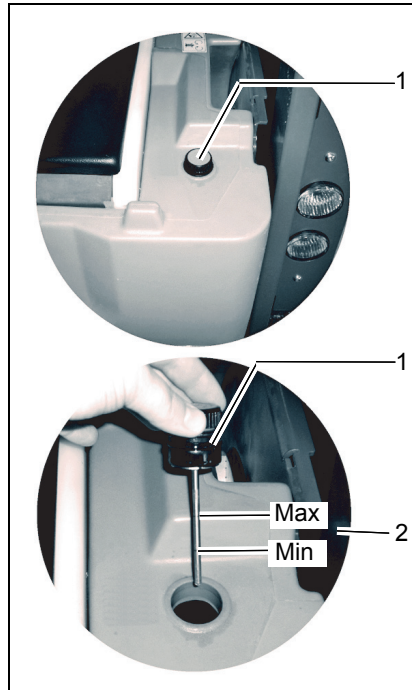

Fig.24

5.10 V-Belt Drive

- 1 Suction fan V-belt (75 Hz)
- 2 Tensioning roller for dynamo
- 3 V-belt pulley
- 4 Hydraulic pump V-belt
- 5 Belt guide
- 6 Hexagonal nut
- 7 V-belt for sweeper roller
- 8 Hydraulic pump belt pulley
- 9 Coupling roller for sweeper roller
- 10 V-belt for sweeper roller
- 11 Belt pulley for sweeper roller
- 12 Tension spring
- 13 Tensioning roller lever
- 14 Tension spring
- 15 Tensioning roller
- 16 Tensioning roller lever for sweeper roller drive
- 17 V-belt pulley for suction fan
- 18 V-belt for dynamo(50 Hz)
- 19 Belt pulley for hydraulic pump
- 20 V-belt for hydraulic pump (150 Hz)
- 21 Belt pulley for dynamo
- 22 Transmission pulley for sweeper roller drive

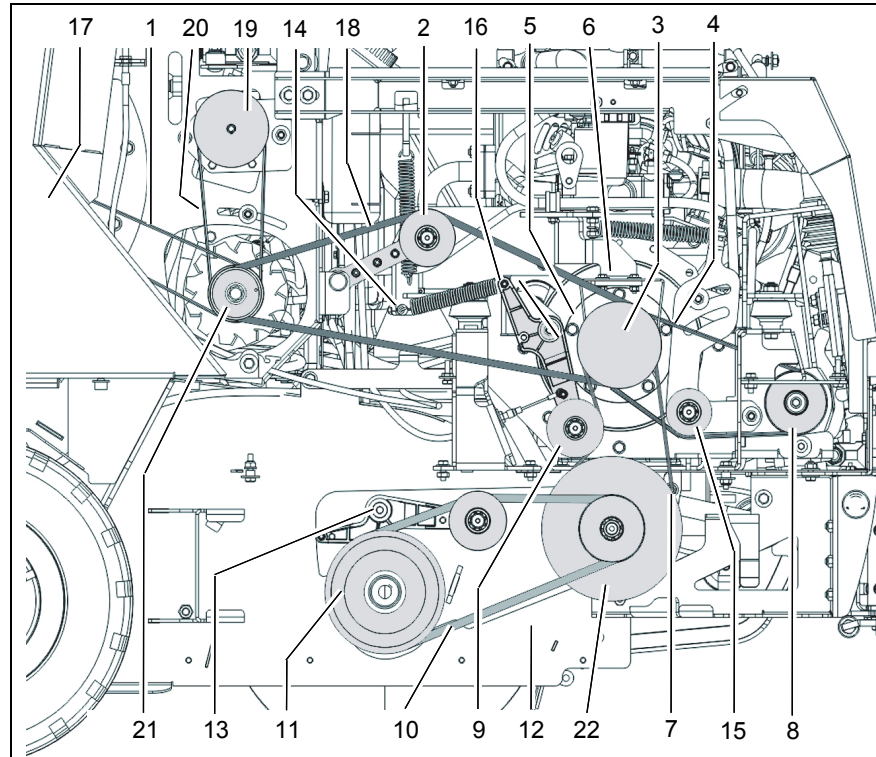

Fig.25

Maintenance and Care

5.11 Electric System

5.11.1 Fuses and relays

- 1 Pre-fuse (F1=15A)
- 2 Supply unit control perm.(F2=7,5A)
- 3 Supply unit control connected(F3=10A)
- 4 Horn, oil pressure, option side broom left (F4=10A)
- 5 Electric lighting (F5=15A), option
- 6 Electric lighting (F6=10A), option
- 7 Parking and rear light left (F7=5A), option
- 8 Parking and rear light right (F8=5A), option
- 9 Vibratory motor (F9=35A)
- 10 Warning light and rotating beacon (F10=10A), option
- 11 Side broom left (F11=4A), option
- 12 Control voltage preheat (only diesel) (F12=10A)
- 13 Control voltage preheat (only diesel) (F13=10A)
- 14 K1 Control unit (K1)
- 15 Automatic monitoring for filter (K4)
- 16 Shaking device (K5)
- 17 Auxiliary relay(K2)
- 18 Auxiliary relay (K3)

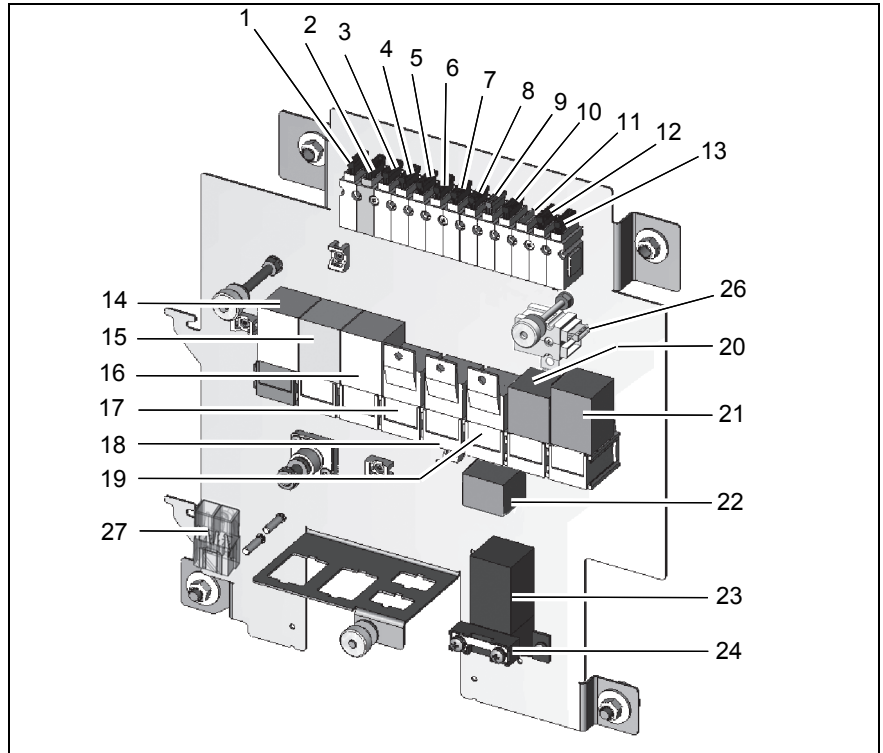

Fig.26

Maintenance and Care

- 19 Dim light or head lamps (K6), option
- 20 Flasher unit (K7), option
- 21 Timer generator (K9)
- 22 Switch off engine (K10)
- 23 Pre-heater relay (K8) (only diesel)
- 24 Heater plugs (F14)(only diesel)
- 25 Main fuse (F0=50A)
(below the battery)
- 26 Switch off engine (F20)
- 27 Fleetrecorder relay (K20/K21),
option

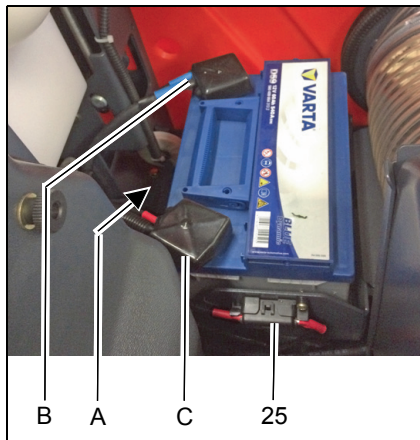

Fig.27

5.11.2 Batterie



Wear protective gloves and safety goggles. Do not place metal objects or tools on batteries - risk of short circuit! Ensure that sufficient ventilation is provided in the charging area when charging the batteries - risk of explosion! Keep the seat hood open when charging the battery!

Removing the battery

1. Turn off the engine and remove the ignition key.
2. Hold the machine with the parking brake. Allow the engine to cool down.
3. Remove the right side panelling and release the battery holder (Fig. 27/A).
4. Disconnecting the battery: disconnect the minus pole (Fig. 27/B) first, then the plus pole (Fig. 27/C)!
5. Remove the battery. Clean and grease the battery poles.
6. Recharge the battery or replace it by a new battery of the same strength.

7. Connecting the battery: connect the plus pole (Fig. 27/C) first, then the minus pole (Fig. 27/B).

Maintenance and Care

5.12 Special Equipment and Spare Parts

Designation	Description	Order no.
Protective roof	For Sweepmaster	6304
Side broom system, left	With deflector plate, without brush	6336
Rotating beacon	For mounting on the protective roof	6305
Rotating beacon	For direct fitting	6306
High-performance filter	Superfine filter with special coating for dust-free sweeping in problematic areas	see spare part catalogue
Comfort seat	Seat features adjustable cushioning	7093
Silence Kit	For use within noise-sensitive areas	6339
Solid rubber tyres	Set of puncture-safe SE-Superelastic-tyres 4.00-4 (2 rear wheels on rim)	6334
Solid rubber tyres	Set of puncture-safe SE-Superelastic-tyres 4.00-4, leaving no traces (2 rear wheels on rim)	6335
Lighting system	Front lights (according to german StVZO)	6302
Sweeper roller	PA bristling	6312
Side broom	PA bristling (PA 1,5)	6414
Side broom	PA bristling (PA 2)	6423

Maintenance and Care

EC-Declaration of Conformity (according to Directive 2006/42/EC)

Hako GmbH
Hamburger Straße 209-239
D-23843 Bad Oldesloe

declare under our sole responsibility,
that the product

Sweepmaster P1200 RH
Type: 6300.10
Sweepmaster D1200 RH
Type: 6300.20

to which this declaration relates corresponds to the relevant basic safety and health requirement of the Directive 2006/42/EC and 2014/53/EC.

For the relevant implementation of the safety and health requirements mentioned in the Directives, the following standard (s) and / or technical specification (s) has (have) been respected:

EN 60335-2-72
EN 55012
EN 61000-6-2

Bad Oldesloe, 23.01.2018



Ricardo Ruiz Porath
Product line Manager
Cleaning Technology

Name of the person authorised for Hako to compile the technical file:

Ludger Lüttel



88-10-2736 - 4480-19

Hako GmbH
Head Office
Hamburger Str. 209-239
23843 Bad Oldesloe
Germany
Tel. +49 4531 806-0
info@hako.com
www.hako.com